

Sea Ray Owner's Manual

Sea Ray 

185 Sport

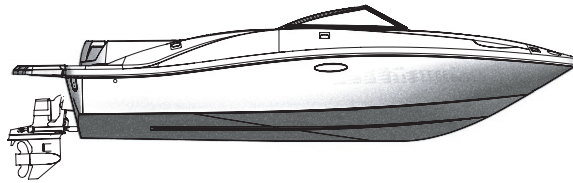

Owner's Manual Part Number: MRP 1801048

WELCOME

185 Sport



Congratulations on becoming the new owner of the world's most prestigious boat. We at Sea Ray® Boats, Inc. welcome you into our worldwide and ever-expanding family of boating enthusiasts.

The Owner's Manual Packet, to be kept on board your Sea Ray, gives you important information on all the features of your Sea Ray. For years of trouble-free boating take the time to carefully review the information in your Owner's Manual Packet and really get to know your boat. **Have everyone who will operate your boat read this manual.**

The Owner's Manual Packet contains the following:

- **Owner's Manual**

The Owner's Manual gives you important operating and safety information, as well as reminding you about your responsibilities as a boat owner/operator.

- **Original Equipment Manufacturer (OEM) Information**

This section of your Owner's Manual Packet contains information from the manufacturers of equipment installed on your boat. Examples include the engine, engine control and steering system. Throughout the Owner's Manual you will be referred to information provided by manufacturers of specific systems.

Because your purchase represents a substantial investment, we know you will want to take the necessary measures to protect its value. We have outlined a program for proper operation, periodic maintenance and safety inspections. We urge you to follow these recommendations. If you have questions which are not fully covered by the Owner's Manual Packet, please consult your authorized dealer for assistance.

Thank You For Selecting A Sea Ray®!

Bon Voyage

Sea Ray®



THIS PAGE LEFT INTENTIONALLY BLANK



INTRODUCTION

1. THIS MANUAL

The material here and in the rest of the Owner's Manual Packet:

- Gives you basic safety information;
- Describes the features of your boat;
- Describes the equipment on your boat;
- Describes the fundamentals of boat use; and
- Contains service and maintenance information.

You must learn to operate this boat as well as read, understand and use this manual.

What this manual does not give you is a course in boating safety, or how to navigate, anchor or dock your boat. Operating a power boat safely requires more skills, knowledge and awareness than is necessary for a car or truck.

2. YOUR RESPONSIBILITIES

For your safety, the safety of your passengers, other boaters and people in the water, you must:

- Take a boating safety course;
- Get instruction in the safe and proper handling of your boat;
- Understand and follow the "rules of the road";
- Learn how to navigate.
- Registration: In addition to the registration requirements for your boat in the state where it is used most frequently, many states require additional registration when an out-of-state boat is used within their boundaries. Contact state boating authorities or any marine dealer for registration requirements.

3. SOURCES OF INFORMATION

In North America, contact one of the following for boating courses:

- U.S. Coast Guard Auxiliary
- U.S. Power Squadron
- Canadian Power and Sail Squadrons
- Red Cross
- State Boating Offices
- Yacht Club

Contact your dealer or the Boat/U.S. Foundation at
1-800-336-2628

Outside of North America, contact your boat dealer and/or your governmental boating agency for assistance.

A book that provides a comprehensive background in boating is Chapman - Piloting, Seamanship and Small Boat Handling, by Elbert S. Maloney, published by Hearst Marine.



INTRODUCTION

4. DEALER RESPONSIBILITIES

In addition to a predelivery check and service of the boat, your dealer is to give you:

- A description and demonstration of the safety systems, features, instruments and controls on your boat;
- An orientation in the general operation of your boat;
- An “In Service Check List” form completed by you and the dealer after your inspection of the boat;
- A review of all warranty information and how to obtain warranty service;
- The complete Owner’s Manual Packet.

If you do not receive all of these materials, or have any questions, contact your dealer or call: 1-800-SRBOATS.

5. WARRANTIES

Your boat comes with several warranties. Each component and/or system on your boat has its own warranty that will be found with the specific information and manual for that component. These are included with your Owner’s Manual Packet. Locate and read the individual warranties; then put them together for easy future reference. The Sea Ray® warranty is on the warranty information sheet in your packet.

6. HULL IDENTIFICATION NUMBER (HIN)

The “Hull Identification Number” located on the starboard side of the transom, is your boat’s most important identifying factor and must be included in all correspondence and orders. Failure to include it creates delays. Also of vital importance is the engine serial number and part number when writing about or ordering parts for your engine. Refer to the Engine Operator’s Manual for location of engine serial number and record it for future reference.

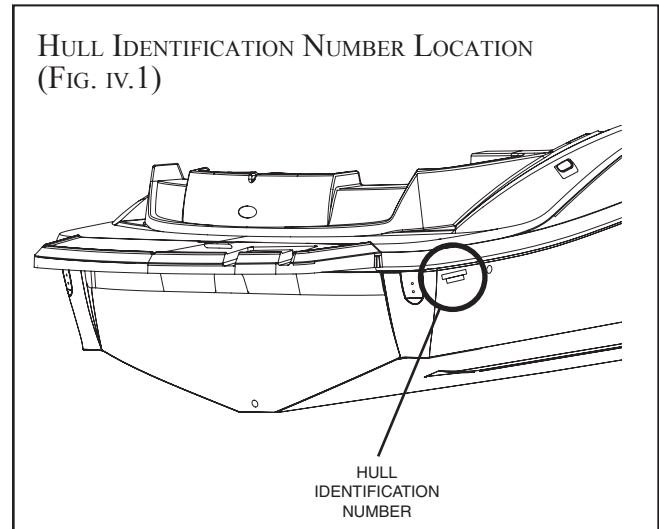

INTRODUCTION

7. MANUFACTURER'S CERTIFICATION

As a boat manufacturer, Sea Ray builds their products to guidelines established under the Federal Boat Safety Act of 1971. The Act is promulgated by the United States Coast Guard who has authority to enforce these laws on boat manufacturers that sell products in the United States. Sea Ray ensures that all of its products comply with these laws.

The NMMA, National Marine Manufacturers Association, provides Sea Ray with a third party certification. The NMMA is an organization that represents the marine industry and assists manufacturers, boat dealers, marinas, repair yards and component suppliers in areas of legislation, environmental concerns, marine business growth and state and federal government agency interaction. The third party certification that Sea Ray participates in, uses the well known Standards and Recommended Practices of the ABYC, American Boat and Yacht Council.

Sea Ray Boats participates extensively in the American Boat and Yacht Council which is a nonprofit organization that develops and publishes voluntary standards and recommended practices for boat and equipment design, construction, service and repair. We utilize all applicable ABYC standards in the construction of your Sea Ray boat.

Finally, Sea Ray sells their products world wide and as such must conform to the various rules and regulations required by other countries. Most notably, are the ISO standards in Europe which require the application of the CE (Common European) mark. This mark, much like the NMMA certification here in the US, gives you the boat owner specific information concerning your craft. For more on this, turn to Section 1 • Safety, subsections 8 and 13 which explains in detail the CE plate and its importance.

8. SERVICE, PARTS AND REPAIR FOR YOUR BOAT

When your boat needs service, parts or repair, take it to an authorized Sea Ray® dealer. To find a dealer in your area call:

Domestic: 1-800-SRBOATS

Fax: 1-314-213-7878

(International: 1-314-216-3333)

or on the Internet at www.searay.com

To find repair and parts facilities for the equipment installed on your boat, refer to the manual for that component.

If a problem is not handled to your satisfaction:

1. Discuss any warranty-related problems directly with the service manager of the dealership or your sales person. Give the dealer an opportunity to help the service department resolve the matter for you.
2. If a problem arises that has not been resolved to your satisfaction by your dealer, contact Sea Ray® Boats at 1-800-SRBOATS (International 1-314-216-3333) and the appropriate customer service department information will be provided to you.





ABOUT YOUR LIMITED WARRANTY

Sea Ray offers an express Limited Warranty on each new Sea Ray purchased through an authorized Sea Ray dealer. A copy of the Limited Warranty was included in your owner's manual packet. If for any reason, you did not receive a copy of the Limited Warranty, please contact your local dealer or call 1-800 SR BOATS for a replacement copy. This is a summary of several provisions of the Limited Warranty. Please read the Limited Warranty, which is the controlling document.

Under the Limited Warranty, Sea Ray covers: (a) structural fiberglass deck or hull defects which occur within five (5) years of the date of delivery; (b) parts found to be defective in factory material or workmanship within one (1) year of the date of delivery; (c) laminate blisters resulting from defects in factory material or workmanship for five (5) years on a prorated basis.

Sea Ray's obligation under the Limited Warranty is limited to repair or replacement of parts that are judged defective by Sea Ray and does not include transportation, haul out, or other expenses. The foregoing is the **sole and exclusive** remedy provided by Sea Ray.

The Limited Warranty does not cover engines, stern drives, controls, propellers, batteries, trailers, or other equipment or accessories carrying their own individual warranties, nor does the Limited Warranty cover engines, parts or accessories not installed by Sea Ray. The Limited Warranty does not cover cosmetic gel coat finish. Boats used for commercial purpose are excluded from coverage. **See the Sea Ray Limited Warranty for other exclusions.**

SEA RAY EXPRESSLY DISCLAIMS THE IMPLIED WARRANTIES OF MERCHANTABILITY AND FITNESS. NEITHER SEA RAY NOR THE SELLING DEALER SHALL HAVE ANY RESPONSIBILITY FOR LOSS OF USE OF THE BOAT, LOSS OF TIME, INCONVENIENCE, COMMERCIAL LOSS OR CONSEQUENTIAL DAMAGES.

The unexpired term of the Limited Warranty may be transferred to a subsequent owner upon the new owner's request. The new owner can submit a request for warranty transfer, free of charge, via the searay.com website. Alternatively, the new owner can submit a written request to the Sea Ray Division of Brunswick Corporation, 2600 Sea Ray Blvd., Knoxville, TN 37914, accompanied by a Fifty Dollar (\$50.00) processing fee.

Thank you for your decision to buy a Sea Ray.

The Sea Ray Limited Warranty is subject to change at any time at Sea Ray's discretion. The information contained herein is general information about the Limited Warranty for the owner's general knowledge, but does not alter or amend the terms of the Limited Warranty.



185 SPORT OWNER'S MANUAL • TABLE OF CONTENTS

INTRODUCTION

1. This Manual	iii
2. Your Responsibilities	iii
3. Sources of Information.....	iii
4. Dealer Responsibilities	iv
5. Warranties.....	iv
6. Hull Identification Number (HIN).....	iv
7. Manufacturer's Certification	v
8. Service, Parts and Repair for Your Boat	v
About Your Limited Warranty	vi

SECTION 1 • SAFETY

1. Safety Labels	1.1
2. Legally Mandated Minimum Required Equipment	1.2
3. Fire Extinguishing System	1.2
4. Carbon Monoxide	1.2
5. Lifesaving Equipment.....	1.4
6. Additional Recommended Equipment for Safe Operation.....	1.5
7. Impaired Operation	1.5
8. Load Capacity.....	1.5
9. Power Capacity.....	1.6
10. Propellers.....	1.6
11. Stability	1.7
12. Maintain Control.....	1.7
13. Weather	1.8
14. Chart Your Course	1.9
15. Water Sports.....	1.9
A. Swimming	1.9
B. Skiing	1.9
C. Diving.....	1.10
16. Emergency Situations.....	1.11
A. Medical Emergency	1.11
B. Water Rescue	1.11
C. Fire.....	1.11
D. Flooding, Swamping and Capsizing.....	1.12
E. Collisions and Leaking.....	1.12
F. Grounding.....	1.12
G. Propulsion, Control or Steering Failure	1.12
17. Safety Hot Lines	1.13
18. International Requirements	1.13
19. Environmental Considerations.....	1.13
A. Fuel and Oil Spillage.....	1.13
B. Waste Disposal	1.14
C. Excessive Noise	1.14
D. Wake / Wash	1.14
20. Nautical Terms	1.15
21. Key to Symbols on Controls and Prints	1.16
22. Warning Label Locations	1.17

SECTION 2 • GENERAL BOAT ARRANGEMENT

1. Docking/Lifting/Storage.....	2.1
2. Passenger Locations	2.2
3. Basic Boat Dimensions and Clearances	2.3
4. Deck Layout.....	2.4
5. Helm, Gauge & Switch Layout.....	2.5
6. Function and Location of Through-Hull Cutouts ...	2.6
7. Propulsion System.....	2.7
8. Description of Major Controls	2.7
A. Gear Shift and Throttle Control	2.7
B. Power Trim Unit and Gauge	2.8
C. Trailer Switch.....	2.8
D. Engine Alarm System	2.9
9. Important Gauges.....	2.9
A. Tachometer and Hour Meter	2.9
B. Oil Pressure, Water Temperature, Speedometer and Fuel Gauges.....	2.9
C. Magnetic Compass	2.9
10. Navigation and Anchor Lights.....	2.10

SECTION 3 • USING YOUR BOAT

1. Pre-Launch, Launch and Post-Launch Checklist..	3.1
2. Fueling the Boat.....	3.2
3. Boarding	3.3
4. Personal Flotation Devices (PFDs).....	3.3
5. Passenger Instruction and Location	3.3
6. Starting the Engine	3.4
7. Shifting to Drive the Boat	3.5
8. Stopping the Engine	3.6
9. Steering System	3.6

SECTION 4 • BILGE & UNDERWATER GEAR

1. Bilge.....	4.1
A. Fuel and Oil Spillage.....	4.1
B. Drain Plug	4.1
C. Bilge Pump	4.1
D. Bilge Blower	4.2
2. Engine and Stern Drive	4.3
A. Maintenance and Service	4.3
B. Vibration and Causes.....	4.3
C. Impact to Stern Drive.....	4.3
D. Propeller Selection.....	4.4
E. Propeller Removal and Installation	4.4
3. Underwater Gear	4.5
4. Bilge Layout	4.7



185 SPORT OWNER'S MANUAL • TABLE OF CONTENTS

SECTION 5 • FUEL SYSTEM

- 1. Fuel System.....5.1
- 2. Fueling Precautions.....5.2
 - A. Static Electricity and the Fuel System5.2
 - B. General:5.2
 - C. Before and During Fueling Checklist:5.3
 - D. After Fueling Checklist:5.3

SECTION 6 • ELECTRICAL SYSTEM

- 1. DC Electrical System.....6.1
- 2. Ignition Protection6.2
- 3. Fuses6.2
- 4. 12 Volt Accessory Receptacle6.3
- 5. Lighting6.4
- 6. Electrolytic Corrosion and Zinc Anodes.....6.4
- 7. Marine Electronic Cathodic Anti-Corrosion System6.5
- 8. Electrical Schematics6.5

SECTION 7 • OPTIONS & ACCESSORIES

- 1. Layout and Accessory Locations7.1
- 2. Entertainment Center7.1
- 3. Fire Extinguisher Port7.1
- 4. Automatic Fire Extinguisher System (Optional)7.2
 - A. Extinguisher Indicator Light7.2
 - B. Manual Fire Extinguishing System Pull Handle.....7.2
 - C. Safety Pin7.3
- 8. Canvas.....7.3
 - A. Installation Tips7.3
 - B. Canvas Care and Maintenance7.4
- 9. Horn.....7.4

SECTION 8 • REQUIRED INSPECTION, SERVICE & MAINTENANCE

- 1. Summary Guide for Inspection, Service and Maintenance.....8.1
- 2. Useful Service Information8.3
- 3. Inspection, Service and Maintenance Protocol8.4
 - A. Bilge Area8.4
 - B. Topside and Supplies8.5
- 4. Winterization Checklist for Boats Stored on Land.8.5
 - A. Boat Storage8.5
 - B. Engines8.5
 - C. Battery(ies)8.5
- 5. Fitting out After Storage.....8.6
 - A. Fuel System8.6
 - B. Battery(ies)8.6
 - C. Miscellaneous8.6
- 6. Security Considerations.....8.6
- 8. Quick Reference Checklist.....8.7
 - A. Boarding the Boat*8.7
 - B. Preparing to Depart and After Launching8.8
 - C. While Underway8.9
 - D. Returning to Port.....8.9
 - E. Securing the Boat8.10
 - F. If the Engine Does Not Start.....8.10
- 9. After Market Equipment Checklist8.11
- 10. Maintenance Log8.12

SECTION 9 • CARE & REFINISHING

- 1. Paint Cleaning Agents and Other Substances9.1
- 2. Fiberglass and Gelcoat.....9.1
- 3. Stains and Scratches.....9.2
- 4. Permanently Moored or Docked Boats9.2
- 5. Care for Bottom Paint9.2
- 6. Topside Areas9.2
 - A. Stainless Steel and Alloy Fittings.....9.2
 - B. Salt Crystals.....9.2
- 7. Gauge and Switch Panels9.3
- 8. Acrylic Plastic Sheeting (Plastic Glass)9.3
- 9. Canvas and Clear Vinyl.....9.3
- 10. Exterior Upholstery Fabric9.4

INDEX



185 SPORT OWNER'S MANUAL • TABLE OF CONTENTS

Information in this publication is based upon the latest product specifications available at printing. Sea Ray® Boats, Inc. reserves the right to make changes at any time, without notice, in the colors, equipment, specifications, materials and prices of all models, or to discontinue models. Should changes in production models be made, Sea Ray® is not obligated to make similar changes or modifications to models sold prior to the date of such changes.

Owner's Manual
185 Sport
Printed in the U.S.A. May 2005
© Sea Ray Boats, Inc. • A Brunswick Company
MRP #1801048

Sea Ray Boats, Inc. 2600 Sea Ray Blvd., Knoxville, TN 37914
For information call 1-800-SRBOATS or fax 1-314-213-7878
(International 1-314-216-3333)

Internet Address: <http://www.searay.com>

Note: Not all accessories shown in pictures or described herein are standard equipment or even available as options.
Options and features are subject to change without notice.

The following are registered trademarks of the Brunswick Corporation: Sea Ray® & The SR Wave Logo

Sea Ray 



THIS PAGE LEFT INTENTIONALLY BLANK



SECTION 1 • SAFETY

SAFE BOATING MEANS:

- Knowing the limitations of your boat;
- Following the rules of the road;
- Keeping a sharp lookout for people and objects in the water;
- Not boating in water or weather conditions that are beyond the boat's or the operator's capability;
- Never boating when the operator is under the influence of drugs or alcohol;
- Being aware of your passengers' safety at all times; and
- Reducing speed when there is limited visibility, rough water, nearby people in the water, boats, or structures.

Boating in beautiful weather and calm water conditions can be a wonderful experience. Pleasurable boating, however, requires considerably greater skills than operating a land vehicle. To obtain these skills, you must:

- Take a Coast Guard, U.S. Power Squadron or equivalent boating safety course. **Call the Boat/U.S. Foundation at 1-800-336-2628 for information on available courses.**
- Get hands-on training on how to operate your boat properly.

IN ADDITION:

- Maintain your boat and its safety and other systems as recommended in this manual.
- Have the boat inspected by a qualified mechanic or dealer, at least annually.
- Ensure that the Coast Guard required safety equipment is on board and functions. (See page 1.2).

1. SAFETY LABELS

Safety precautions are given throughout this manual and labels are mounted at key locations throughout the boat. This safety information advises the owner/operator and passengers of imperative safety precautions to follow when operating and/or servicing equipment.

- Fig. 1.17.1 thru 1.18.1 show the location of the safety labels on your boat.
- Do not remove or obstruct any safety label.
- Replace any label which becomes illegible. Replacement safety labels can be obtained by calling your dealer or Sea Ray at 1-800-SRBOATS (International 1-314-216-3333) for information on how to contact the manufacturing facility for your boat.

The meaning associated with each of the four basic types of label is:



DANGER

DANGER – Immediate hazards which **WILL** result in severe personal injury or death if the warning is ignored.



WARNING

WARNING – Hazards or unsafe practices which **COULD** result in severe personal injury or death if the warning is ignored.



CAUTION

CAUTION – Hazards or unsafe practices which could result in minor injury or product or property damage if the warning is ignored.

NOTICE

Information which is important to proper operation or maintenance, but is not hazard-related.



SECTION 1 • SAFETY

2. LEGALLY MANDATED MINIMUM REQUIRED EQUIPMENT

Consult your national boating law enforcement agency.

The following equipment is the minimum required by the U.S. Coast Guard for a boat less than 26' [7.9 meters] in length.

Personal Flotation Devices (PFD's): One Coast Guard approved Type I, II or III device is mandatory for each person aboard. One throwable Type IV device is also required to be on board. A Type V device is acceptable if worn for approved use. See Page 1.4 for a description of these PFD classifications. **Always wear a PFD when boating.**

Fire Extinguisher - Portable: If no fixed fire extinguishing system is installed in the engine and generator spaces, the U.S. Coast Guard requires **one (1) Type B-1** fire extinguisher be on board. The American Boat and Yacht Council (ABYC) recommends that you have **two (2) Type B-1 ABC** fire extinguishers on board. One is to be located at the helm station and the other in the cabin, near the cockpit door. On boats with no enclosed cabin, the second fire extinguisher may be located in the cockpit area.

Whistle, Horn: You must have on board some means of making a loud sound signal, for example, whistle or horn.

Visual Distress Signals: If you operate your boat in coastal waters or on the Great Lakes, you must have visual distress signals for day and night use on board. At least three (3) U.S. Coast Guard approved pyrotechnic devices marked with date showing service life must be carried, be readily accessible, in serviceable condition and not expired. Store pyrotechnic signals in a well-marked waterproof container in a dry location.

Other: Your Sea Ray is equipped with the required navigation lights, engine exhaust and ventilation systems.

3. FIRE EXTINGUISHING SYSTEM

Your boat must be equipped with the fire extinguishing equipment mandated by the U.S. Coast Guard. Your boat is equipped with a fire extinguisher discharge port located below the transom seat back cushion (see page 7.1).

IF A FIRE IS SUSPECTED, IMMEDIATELY SHUT DOWN THE ENGINE, POWERED VENTILATION, ELECTRICAL SYSTEMS AND EXTINGUISH ALL SMOKING MATERIALS.

IF THERE IS A FIRE IN THE ENGINE COMPARTMENT DO NOT OPEN THE ENGINE HATCH. THIS WOULD FEED OXYGEN TO THE FIRE AND THE FIRE COULD RESTART.

DISCHARGE PORTABLE FIRE EXTINGUISHER THROUGH THE DISCHARGE PORT BELOW THE TRANSOM SEAT BACK CUSHION.

Wait at least fifteen (15) minutes before opening the engine compartment. This gives the compartment long enough for hot metals and fuels to cool. Have portable extinguishers at hand and ready to use in case the fire reignites. Do not breathe fumes or vapors caused by the fire.

4. CARBON MONOXIDE

Symptoms of carbon monoxide poisoning are dizziness, ears ringing, headaches, nausea and unconsciousness. A poisoning victim's skin often turns cherry red. Because carbon monoxide gas (CO) is odorless, colorless and tasteless, it is unlikely to be noticed until a person is overcome.

DANGER

Fumes from engine, generators, and other equipment and appliances using burning fuel contain carbon monoxide.

Carbon Monoxide can kill you.

Open all doors, curtains, windows, and hatches to let fresh air circulate, when running engine, generator or burning any fuel when boat is anchored, moored or docked.



SECTION 1 • SAFETY

⚠ DANGER

Even in rainy cold weather ventilation must be maintained to avoid Carbon Monoxide poisoning. You will get wet and/or cold.

⚠ DANGER

Sleeping on boat requires an operating Carbon Monoxide detection system in each sleeping location.

Dangerous concentrations of carbon monoxide will be present if:

- the engine and/or generator exhaust systems leak;
- insufficient fresh air is circulating where people are present; and/or
- fumes move from the rear of the boat into the cockpit and cabin area.
- Be sure to have sufficient ventilation when using canvas or window-type side curtains when underway, anchored, moored or docked.
- If the convertible top is installed, operate with the forward hatch open.
- Operate all burning fuel appliances, such as charcoal, propane, LPG, CNG or alcohol cooking devices in areas where fresh air can circulate. Do not use such devices where there is no noticeable air movement, especially in the cabin, when anchored, moored or docked.
- Do not idle engine without moving boat for more than 15 minutes at a time.
- Inspect the exhaust system regularly. (See Section 8 • Required Inspection, Service & Maintenance.

Fig. 1.3.1 gives examples of boat operating conditions that can lead to high concentrations of carbon monoxide gas.

To minimize the danger of CO accumulation when the engine is running, or using burning fuel applications:

If CO poisoning is suspected, have the victim breath fresh air deeply. If breathing stops, resuscitate. A victim often revives, then relapses because organs are damaged by lack of oxygen. Seek immediate medical attention.

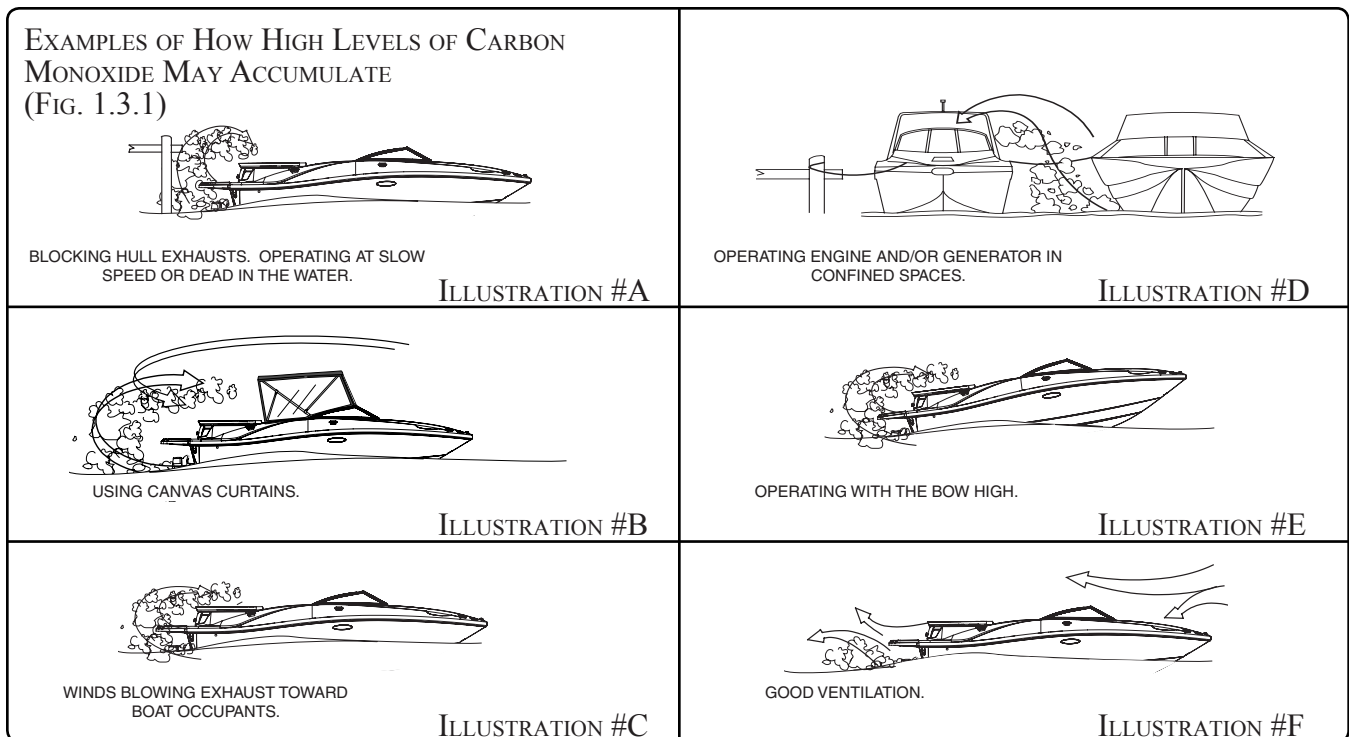

5. LIFESAVING EQUIPMENT

Even strong swimmers can tire quickly in the water and drown due to exhaustion, hypothermia, or both. The buoyancy provided by a personal flotation device (PFD) will allow the person who has fallen overboard to remain afloat with far less effort and heat loss, extending survival time necessary to find and retrieve them.

Boat operators are required to carry one wearable personal flotation device (Type I, II, III or V) for every person on board. Boats must also have at least one throwable device (Type IV).

The law requires that PFD's must be readily accessible, if not worn. "Readily accessible" means removed from storage bags and unbuckled. But, children and nonswimmers must wear PFDs at all times when aboard. It is common sense to have everyone on board wearing PFDs. A throwable device must also be right at hand and ready to toss.

A. PFD CLASSIFICATIONS

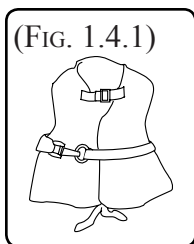

Off-Shore Life Jacket (Type I) – most buoyant, it is designed to turn an unconscious person face up; used in all types of waters where rescue may be slow, particularly in cold or rough conditions.

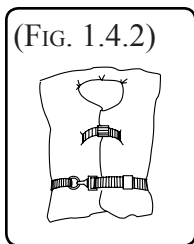

Near-Shore Life Vest (Type II)– "keyhole" vest with flotation-filled head and neck support is also designed to turn a person face up, but the turning action is not as pronounced; used in calm, inland waters or where quick rescue is likely.

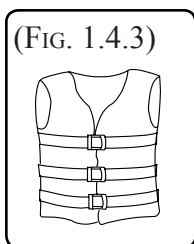

Flotation Aid (Type III) – vest is designed so conscious wearers can turn face up; often designed for comfort while engaged in sports such as skiing.

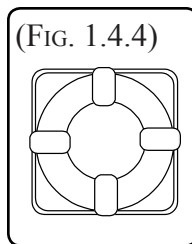

Throwable Devices (Type IV)– horseshoe buoys, ring buoys and buoyant cushions are designed to be grasped, not worn.

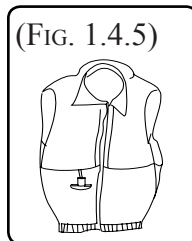

Special-Use Devices (Type V)– sailboat harnesses, white-water vests, float coats, and hybrid vests which have minimum inherent buoyancy and an inflatable chamber.

Before purchasing PFDs, ensure that there is an attached tag indicating they are approved by the U.S. Coast Guard or by your national boating law enforcement agency.

Children and nonswimmers must wear PFDs at all times when aboard. All passengers and crew should wear them. A loose PFD is often useless in an emergency.

The operator is responsible for instructing everyone aboard on the location and use of PFDs.

Size PFDs for the wearer. Children require special attention in the use of PFDs.

Test PFD buoyancy at least once a year.

SECTION 1 • SAFETY

6. ADDITIONAL RECOMMENDED EQUIPMENT FOR SAFE OPERATION

In addition to legally mandated equipment, the following items are necessary for safe boating, especially if your boat is out of sight of land.

- First aid kit
- Visual distress signals for day and night use (required in some areas; consult local regulations)
- Charts of your intended cruising area
- Compass
- GPS or Loran position locating devices
- Marine VHF radio with weather channels
- Emergency position-indicating radio beacon (EPIRB)
- Manual bilge pump
- Moisture repellent
- Anchors, chain and line (The anchors must be properly sized for your boat. Ask your dealer or marine supply store for recommendations).
- Mooring lines
- Fenders
- Boat hook
- Waterproof flashlight(s)
- Extra batteries for flashlights and portable electronic devices
- High power spotlight, if you intend to boat at night
- Spare keys
- Instruction manuals for engine and accessories
- Lubricating oil
- Tool kit:
 - Assorted screwdrivers (Phillips and flat blade)
 - Pliers (regular, vise-grip, and tongue & groove)
 - Wrenches (box, open-end, allen, adjustable)
 - Socket set (metric or U.S. Standard as appropriate)
 - Electrical tape and duct tape
 - Hammer
 - Utility Knife

- Spare parts kit (spark plugs, fuses, hose clamps and ask your dealer to recommend other parts)
- Extra propeller

7. IMPAIRED OPERATION

Drugs and/or alcohol will prevent you from operating your boat safely. This single factor is involved in more marine accidents and deaths than any other. The detrimental effects of alcohol and drugs are increased by the wind, waves and sun, quickly impairing your ability to react properly and promptly in an emergency.

WARNING

Drugs and/or alcohol impair the operator's ability to control the boat safely.

Death or serious injury can result from improper boat operation.

8. LOAD CAPACITY

The certification plate (See Fig. 1.6.1 and 1.6.2) located near the helm indicates maximum weight and number of persons your boat can handle under calm sea conditions. **Do not exceed the load capacities stated.** The number of people on board must be reduced if you go out in poor weather and rough water.

The information present on the certification plate does not relieve the operator from responsibility. Use common sense and sound judgement when placing equipment and/or passengers in your boat.

- Do not load to capacity in poor weather or rough water.
- The number of seats does not indicate how many people a boat can carry in poor weather and rough water.
- Above idle speed, all passengers must be seated on the seats provided.



SECTION 1 • SAFETY

BUILDER'S PLATE (DOMESTIC)
(FIG. 1.6.1)

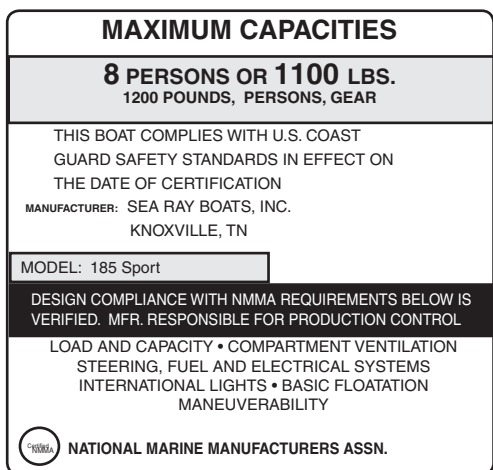

9. POWER CAPACITY

Your boat's engine and accessories were selected to provide optimum performance and service. Installing a different engine or other accessories may cause unwanted handling characteristics. Should you choose to install a different engine or to add accessories that will affect the boat's running trim, have an experienced marine technician perform a safety inspection and handling test **before** operating your boat again. Certain modifications to your boat **will** result in cancellation of your warranty protection. **Always** check with your dealer **before** making any modifications to your boat.

BUILDER'S PLATE (INTERNATIONAL)
(FIG. 1.6.2)

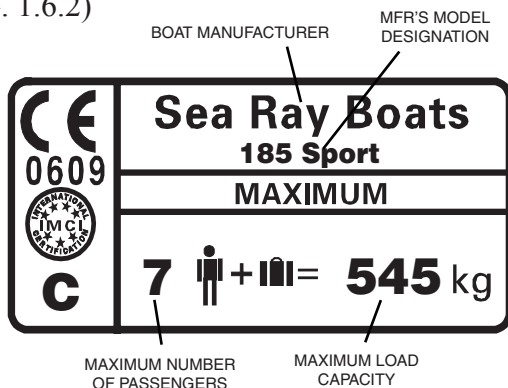

10. PROPELLERS

Your Sea Ray® has been equipped with a propeller which our tests have shown to be the best suited for general use with our engine under normal conditions and load. Do not change the pitch of your propeller without getting your dealer's recommendations first. If you change to a different propeller pitch, **under no circumstances use a propeller which allows the engine to operate at higher than recommended RPM.** (Your engine manual specifies the maximum recommended RPM).

To maintain rated power, propellers should be free of nicks, excessive pitting and any distortions that alter them from their original design. Badly damaged propellers should be replaced, but those that are chipped, bent or merely out of shape can be reconditioned by your marine dealer.

It is advisable to carry an extra propeller aboard in case you damage the one in use.

WARNING

When engine is running, keep passengers away from areas not designed for riding, such as seat backs, bow, gunwales, transom platform, swim platform, front and rear decks and on sun pads.

Passengers can fall overboard if not seated properly on the seats provided.

DANGER

Never carry more weight or passengers than indicated on the certification plate, regardless of weather or water conditions.

The boat can capsize, swamp or sink.



SECTION 1 • SAFETY

11. STABILITY

Your boat was manufactured to specific stability and flotation standards for the capacity shown on the certification plate. Any increase from the recommended load capacities will put your boat in jeopardy of capsizing, swamping and/or sinking.

IN ADDITION:

- Stability may be substantially reduced if equipment is added above the deck.
- Stability is substantially reduced by loose fluids or weight within the hull. Keep bilge area as dry as possible, and close all openings, hatches and windows in rough weather.

WARNING

Distribute passengers and gear as uniformly as possible from front to rear and left to right.

The manufacturer's load rating is the maximum allowed under calm conditions.

Reduce boat loading if weather, water or other conditions are adverse.

12. MAINTAIN CONTROL

On the water there are no marked traffic lanes, no traffic signs or lights, and boats have no turn signals. The boat operator must keep his or her attention focused not only on what's ahead but what's on the left, right and behind the boat.

The operator must always be alert to approaching boats (from the rear, right and left sides, as well as those ahead). There can be people in the water, partially submerged debris, and other navigational hazards such as rocks, sand bars, dangerous currents, to name a few.

Your passengers are relying on you to operate and maneuver the boat safely so that they are not in danger of going overboard. If you turn too quickly, increase or decrease speed abruptly, your passengers are at risk of being thrown overboard or thrown about the boat.

When visibility becomes impaired because of weather, time of day or high bow angle you must slow down so that you have sufficient time to react if an emergency occurs. Nearby boats face similar risks in avoiding a collision with you.

A. GENERAL CONSIDERATIONS

- Know how your boat handles under different conditions. Recognize your limitations and the boat's limitations. Modify speed in keeping with weather, sea and traffic conditions.
- Instruct passengers on location and use of safety equipment and procedures.
- Instruct passengers on the fundamentals of operating your boat in case you are unable to do so.
- You are responsible for passenger's actions. If they place themselves or the boat in danger, immediately correct them.

WARNING

Death or serious injury can result if you fail to observe these safety rules:

- **Anyone who controls the boat must have taken a boating safety course and have trained in the proper operation of the boat.**
- **Always operate the boat at speeds that will not put people or property in danger.**
- **Be constantly aware of conditions in all directions when underway and before turning.**
- **Reduce speed, use a lookout to identify possible hazards or difficulties, and turn on navigation lights when:**
 - **visibility is impaired;**
 - **in rough water; or**
 - **in congested waterways.**
- **Watch your wake. It can capsize a small boat or damage moored boats or other property. You are responsible for damage caused by your wake.**



13. WEATHER

There are four design categories of boats based upon their ability to withstand wind and sea or water conditions:

A. Ocean

Wind speed: above 40 knots (46 mph)
Wave height: above 4 meters (13 feet)
Boat may be used for extended ocean voyages.

B. Offshore

Maximum wind speed: 40 knots (46 mph)
Maximum wave height: 4 meters (13 feet)
Boat can be used offshore, but not for extended ocean voyages.

C. Inshore

Maximum wind speed: 27 knots (31 mph)
Maximum wave height: 2 meters (6.5 feet)
Boat use is limited to coastal waters, large bays, estuaries, lakes and rivers.

D. Sheltered waters

Maximum wind speed: 15 knots (18 mph)
Maximum wave height: 0.5 meters (1.5 feet)
Boat use is limited to small lakes, rivers and canals.

Getting caught in severe weather is hazardous. Bad weather and/or rough sea or water conditions can cause an unsafe situation. Consult local weather information, or listen to the NOAA weather reports for the latest weather conditions or any impending deterioration of the weather before setting out and while underway. Following are a few basic weather-related rules:

- Check the weather forecast and the water conditions before leaving and while underway.
- A sudden change in wind direction or speed or an increase in wave height indicates deteriorating weather.
- Have everyone wear a personal flotation device.
- If a storm approaches, immediately seek a safe harbor.
- If a storm hits, have everyone sit in the cabin or on the cockpit deck in the boat. Head the bow into the wind with enough power to maintain slow headway.
- If you encounter fog, determine your position, set a safe course, slow down and alert other boats of your presence with a sound signal.
- If a lightning storm approaches, the safest action is to dock and disembark. If you cannot return to shore, have passengers go **inside** the cabin and remain there until the storm passes.
- Lightning seeks a ground when it strikes. The best protection is a properly grounded lightning rod placed high enough over the deck to provide a protective umbrella over the hull. Depending upon the likelihood of your being in a lightning storm, consult your dealer for installation of a lightning rod. Stay clear of the lightning rod, all attached wiring and all metal parts of the boat.
- Stay out of the water during a lightning storm. If caught swimming during a storm, get back into the boat and remain there until the storm passes.

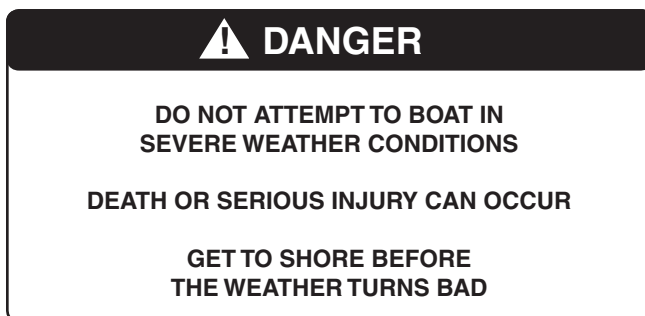

Your 185 Sport is Design Category C.

The wind speed and wave height specified as the upper limit for your category of boat does **not** mean that you or your passengers can survive if your boat is exposed to these conditions. It is only the most experienced operators and crew that may be able to operate a boat safely under these conditions. You must always be aware of weather conditions and head for port or protected waters in sufficient time to avoid being caught in high winds and rough water. **Do not take chances!**



SECTION 1 • SAFETY

14. CHART YOUR COURSE

WARNING

Hitting an object in or under the water or boating in dangerous currents can cause serious injury or death to boat occupants.

You must know where the hazards are and avoid them.

In uncharted waters, boat very slowly and post a lookout.

To avoid boating in unsafe areas where there are underwater obstructions, shallow water, unnavigable conditions such as dangerous currents, and others, you must chart a course. This means having and using the National Oceanic and Atmospheric Administration (NOAA) charts for coastal waters, observing and understanding all navigational aids, using the knowledge and guidance of experienced boaters, and being aware of the tide times where appropriate.

WARNING

Shut engine off if an object is struck or if you run aground.

Check for hull leaks and drive line damage, before restarting engines.

Use hand pump if bilge pumps don't remove water.

Boat very slowly, if you must proceed with a damaged drive line.

If you are in an unfamiliar area without knowledge of the hazards, proceed very slowly and have someone watch for hazards.

Let others know where you are going. A float plan describes your intended cruising course and itinerary, boat description, and your expected time and date of return. Give the float plan to a friend or relative, so they can give the information to a national boat agency, like the U.S. Coast Guard, in the event you fail to return.

15. WATER SPORTS

WARNING

Your boat can kill or injure persons in the water.

Always stay away from areas designated for swimming or diving. Unless you are towing a skier, stay away from water ski areas. Recognize markers used for such areas.

When engine is running, close and lock transom door and do not permit anyone to use boarding ladder or swim platform.

A. SWIMMING

- Do not permit anyone to swim from a moving boat, or a boat with an engine running.
- Many localities prohibit swimming from boats except in designated areas.
- Make sure boat's engines are turned off before allowing people to swim anywhere near your boat. Shut the engine OFF and remove the key from the ignition switch so that no one can accidentally start the engine while swimmers are nearby.
- Turn off engines when taking swimmers or skiers aboard or when they are entering the water. Never permit use of the transom or swim platform while engines are running.
- Slow down and look for swimmers or skiers when cruising in an area where there might be persons in the water.

B. SKIING

WARNING

Skiers must wear an approved PFD.

It is advised that you become familiar with water skiing safety and hand signals as you will most likely, on occasion, find yourself in the vicinity of or engaging in water skiing activity.

- Anyone who water skis must know how to swim.



SECTION 1 • SAFETY

- Never drive the boat directly behind a water skier. At 22 knots (25 m.p.h.), it takes only 5 seconds to overtake a fallen skier who was 60 meters (200 feet) in front.
- Keep a downed skier in sight and on the operator's side of the boat when approaching the skier. Never back up to anyone in the water.
- Learn the signals to communicate with a skier. The skier is to control the boat through hand signals (Fig. 1.10.1).

Turn – Arm raised, circle with index finger extended.

Skier in Water – Extend one ski vertically out of water.

Back to Dock – Pat top of head.

Cut Motor – Draw finger across throat.

Slow Down – Thumb pointed down or palm down, move hand up and down.

Faster – Thumb pointed up or palm up, move hand up and down.

OK – Raise arm and form a circle with thumb and index finger.

Stop – Raise arm with palm vertical and facing forward.

Turn Right – Extend arm out from body to the right.

Turn Left – Extend arm out from body to the left.

OK After a Fall – Clasp hands together overhead.

- If the skier suddenly releases the tow rope, it can backlash into cockpit. Spotters who are watching the skier must be aware of this fact and be prepared to deflect the rope by hand to avoid injury.

C. DIVING

- Recognize and respect diving flags (Fig. 1.10.2). Keep at least 30 meters (100 feet) away.

Sport Diver's Flag – Red flag with diagonal white stripe marks a diver in the water.

Code Alpha Flag – Blue and white pennant designates boat being used in dive operations.

DIVERS FLAGS
(FIG. 1.10.2)

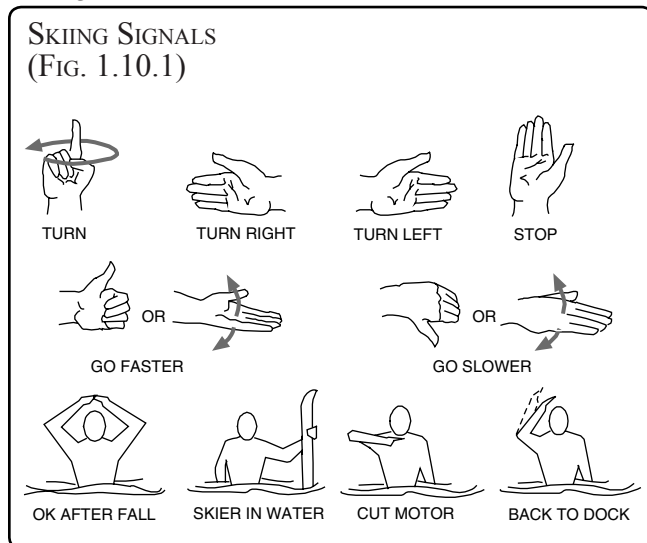
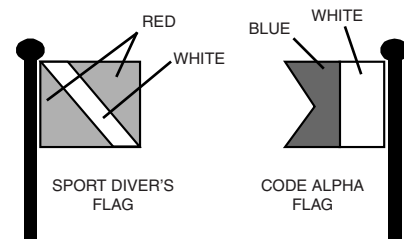

IN GENERAL

When engaged in water sports, be safe and courteous to others sharing the water:

- Be considerate to fishermen.
- Do not water ski in congested areas.
- Keep the boat and skier away from navigation markers.
- Stay well clear of other boats and skiers.



16. EMERGENCY SITUATIONS

Prevention is the safest approach. We hope that you are never involved in an emergency situation.

ASSISTING OTHER BOATERS

All boaters have a legal obligation to help other boaters who are in distress, as long as rendering assistance does not endanger you, your passengers or your boat.

If you are involved in an emergency situation, it is imperative that you know how to react, in order to protect the lives in your care.

A. MEDICAL EMERGENCY

You may be far from professional medical help when you are boating. At least two people on board your boat should be CPR certified, and should have taken a first aid course. Equip your boat with a first aid kit.

B. WATER RESCUE

A person who has fallen overboard will die from hypothermia in water temperatures below 70°F if not rescued quickly. Water rescue consists of three steps: returning to the victim, making contact with the victim, and getting the victim back on board.

RETURNING TO THE VICTIM

- Immediately make everyone aware of the incident and keep the victim in sight.
- Slow the boat and keep pointing toward the person overboard. At night, direct the best available light source at the person.
- Throw a life preserver, even if the person is wearing a PFD. It will serve as another marker.

MAKING CONTACT

- Stop or slow the boat and circle toward the victim.
- Try to approach heading into the wind or into the waves.

- Keep the victim constantly in sight.
- When almost alongside, stop the engine in gear to prevent propeller “windmilling.”

GETTING BACK ABOARD

- Try to reach the victim with a pole, or by throwing a life preserver. Do not swim to rescue the victim, except as a last resort.
- Assist the person in boarding the boat. The person should normally be brought in over the stern.
- If the person is injured or cannot get into the boat, a rescuer should put on a PFD with a safety line attached to the boat and enter the water to assist the victim.
- Handle the victim with care. Spinal injuries may have occurred.

C. FIRE

Fire is a serious boating hazard. Boats will burn quickly. Do not remain on board and fight a fire for more than a few minutes. If the fire cannot be extinguished within a few minutes, abandon the boat.

Have fire extinguishers handy. A small fire can be extinguished quickly with the right size and type of fire extinguisher.

- Extinguish smoking materials, shut off blowers, stoves, engines and generators.
- Throw burning materials overboard, if possible.
- If the fire is accessible, empty the contents of fire extinguishers at the base of the fire.
- If the fire is in the engine compartment and you have an automatic extinguisher for the engine, wait 15 minutes before opening the compartment. Have a portable extinguisher ready in case the fire flares up.
- Signal for help.
- Grab distress signals and survival gear. Put on PFDs. Prepare to abandon ship.



SECTION 1 • SAFETY

D. FLOODING, SWAMPING AND CAPSIZING

In the event of flooding, swamping or capsizing:

- Try to shut off engines, generators and blowers, before leaving the boat.
- Have everyone put on Personal Flotation Devices (PFDs).
- Account for all who were on board.
- If the boat is floating stay with the boat. Hang on, or climb on the boat and signal for help.
- Only as a last resort should you attempt to swim to shore - it is further away than it looks and you can tire and drown.

E. COLLISIONS AND LEAKING

In the event of collision and leaking:

- Slow down or stop to reduce water intake, unless maintaining speed will keep the hole above water.
- Switch on bilge pumps.
- If equipped, operate the manual bilge pump if the powered bilge pumps can't handle the water flow.
- Account for everyone on board and check for injuries.
- Have everyone put on PFDs.
- Stay with the boat.
- Signal for help.
- If a leak patch is attempted, it should be done from the outside.
- In the event of a collision, you are required to file an accident report. Contact a state enforcement agency or the nearest Coast Guard office. If you are boating outside of U.S. waters, consult the nation you are visiting for accident reporting requirements.

F. GROUNDING

In the event of running aground:

- Check for leaks. If water is coming in, stop the intake of water before attempting to get the boat free.
- Inspect for damage to the hull, propulsion and steering systems.
- Determine if the tide, wind and current will drive the boat harder aground or will help to free it.
- Determine the water depth all around the boat, and the type of bottom (sand, mud, rocks, etc.). If it can be done without exposing persons to risk of injury, the boat should be moved away from hard obstructions and toward open water with soft ground.
- Do not attempt to have your boat towed by other than a trained and competent service, such as the Coast Guard or a salvage company. Recreational craft are not designed to tow other recreational craft.

G. PROPULSION, CONTROL OR STEERING FAILURE

If the drive train fails, or controls or steering do not respond properly at all:

- Shut off engine.
- Put out the anchor to prevent drifting.
- Determine whether or not you can repair the problem yourself. See the proper manuals for assistance in troubleshooting the engine, steering and engine controls.
- If you are not sure you can fix the problem, or if conditions are adverse, signal for help.



17. SAFETY HOT LINES

The safety information in the preceding pages gives only the general areas of concern for boating safety. It is not intended to be, nor can it be, exhaustive. You must take a boating safety course, and get hands-on instruction in the proper and safe operation of your boat from experienced persons before cruising.

The U.S. Coast Guard offers many pamphlets on safety and other information not covered in this book. Contact your local Coast Guard unit or call the toll-free safety hot lines below for information.

- U.S. Coast Guard 1-800-368-5647
- Canadian Coast Guard 1-800-267-6687

In other countries, ask your marine dealer for information on how to contact the national boating law enforcement agency.

18. INTERNATIONAL REQUIREMENTS

This vessel and its systems have been constructed in accordance with standards and specifications in effect at the time of manufacture as published by the various regulatory authorities listed below.

1. Ministere De La Mer - France
2. Registro Italiano Navale - Italy
3. Det Norske Veritas - Norway
4. Securite des Nauires - Canada
5. J.C.I. (Japan Craft Inspection) - Japan
6. N.K.K. (Nippon Kaiji Kyokai) - Japan
7. B.S.I. (British Standards Institute) - England
8. Ministerio Obras Publicas Y Transportes - Spain
9. EC Recreational Craft Directive - European Community.

Further information concerning these requirements may be obtained from Sea Ray® Customer Service: 1-800-SRBOATS.

19. ENVIRONMENTAL CONSIDERATIONS

The following warning is offered for boats sold in the State of California in accordance with California Health & Safety Code §§ 25249.5-.13:

WARNING

A wide variety of components used on this vessel contain or emit chemicals known to the State of California to cause cancer and birth defects and other reproductive harm.

EXAMPLES INCLUDE:

- Engine and generator exhaust
- Engine and generator fuel, and other liquids such as coolants and oil, especially used motor oil
- Cooking fuels
- Cleaners, paints, and substances used for vessel repair
- Waste materials that result from wear of vessel components
- Lead from battery terminals and from other sources such as ballast or fishing sinkers

TO AVOID HARM:

- Keep away from engine, generator, and cooking fuel exhaust fumes.
- Wash areas thoroughly with soap and water after handling the substances above.

A. FUEL AND OIL SPILLAGE

Regulations prohibit discharging fuel or oily waste in navigable waters. Discharge is defined as any action which causes a film, sheen or discoloration on the water surface, or causes a sludge or emulsion beneath the water surface. A common violation is bilge discharge. Use rags or sponges to soak up fuel or oily waste, then dispose of it properly ashore. If there is much fuel or oil in the bilge, contact a knowledgeable marine service to remove it. Never pump contaminated bilge discharge overboard. Help protect your waters.

Fill tank(s) less than rated capacity. Allow for fuel expansion.



SECTION 1 • SAFETY

B. WASTE DISPOSAL

- Many areas prohibit overboard sewer discharge. Close and disable flow-through waste systems to prevent discharge in such areas.
- Bag all refuse until it can be disposed of ashore. Regulations prohibit disposal of plastic anywhere in the marine environment and restrict other garbage disposal within specified distances from shore.

NOTICE

- There is a possibility of being fined for having an operable direct overboard discharge of waste in some waters. Removing seacock handle, in closed position, or other means must be used to avoid fine.
- It is illegal for any vessel to dump plastic trash anywhere in the ocean or navigable waters of the United States.

! CAUTION

FOR BOATS WITH VACUFLUSH® HEADS ONLY

Do not place facial tissues, paper towels or sanitary napkins in head. Such material can damage the waste disposal system and the environment.

C. EXCESSIVE NOISE

Many areas regulate noise limits. Even if there are no laws, courtesy demands that boats operate quietly.

D. WAKE / WASH

! WARNING

SPEED HAZARD - Watch your wake. It might capsize a small craft. You are responsible for damage caused by your wake.

Power boat wakes can endanger people and vessels. Each power boat operator is responsible for injury or damage caused by the boat's wake. Be especially careful in confined areas such as channels or marinas. Observe "no wake" warnings.

! CAUTION

Reduce speed in congested waterway.

Be alert for No Wake markers.



SECTION 1 • SAFETY

20. NAUTICAL TERMS

Abeam – object 90 degrees to center line on either side of boat.

Abaft – a point on a boat that is aft of another.

Aft – toward the rear or stern of the boat.

Beam – the width of a boat.

Bow – the fore part of a boat.

Bow Eye – bolt with looped head mounted on extreme forward part of bow.

Bulkhead – vertical partition in a boat.

Chine – meeting juncture of side and bottom of boat.

Chock – deck fitting, used as guides for mooring or anchor lines. Also, a wedge to stop wheels from rolling.

Cleat – deck fitting with arms or horns on which lines may be made fast.

Cockpit – an open space from which a boat is operated.

Deck – upper structure which covers the hull between gunwales.

Draft – depth of water required to float boat and its propulsion system.

Fathom – six feet.

Fenders – rope or plastic pieces hung over the side to protect the hull from chafing.

Freeboard – height of exposed hull from water line to deck.

Ground tackle – general term referring to anchors, anchor lines, etc.

Gunwale (pronounced gun'l) – meeting juncture of hull and deck.

Hatch – an opening in deck to provide access below.

Head – toilet or toilet area in a boat.

Headroom – vertical distance between the deck and cabin or canopy top.

Helm – steering console.

Hull – the basic part of a boat that provides buoyancy to float the weight of the craft and its load.

Keel – the major longitudinal member of a hull; the lowest external portion of a boat.

Knot – unit of speed in nautical miles per hour.

Lee – the side that is sheltered from the wind.

PFD – Personal Flotation Device; life preserver.

Port – term designating left side of the boat.

Rudder – movable fixture at the stern used for steering.

Scupper – hole permitting water to drain overboard from deck or cockpit.

Sheer – curve or sweep of the deck as viewed from the side.

Snub – to check or tighten a line suddenly.

Starboard – term designating right side of the boat

Stern – the aft end of a boat.

Stern drive – outboard unit of an inboard/outboard (I/O) engine installation.

Stringer – longitudinal members fastened inside the hull for additional structural strength.

Transom – transverse part of stern.

Wake – disturbed water that a boat leaves behind as a result of forward motion.









Windward – toward the direction from which the wind is blowing.



SECTION 1 • SAFETY

21. KEY TO SYMBOLS ON CONTROLS AND PRINTS

These symbols may be found on your controls and gauges and/or used in this owner's manual. This page is to help you understand what the symbols mean.

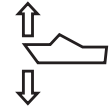
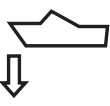
			 ENGINE	 ENGINE START	 ENGINE STOP
 EMERGENCY START SWITCH (TWIN ENGINE ONLY)	 ENGINE EXHAUST CONTROL	 ENGINE ROTATIONAL SPEED	 ENGINE COOLANT	 ENGINE (COOLANT) WATER JACKET TEMPERATURE	 ENGINE OIL PRESSURE
 FUEL, GENERAL	 DIESEL FUEL	 FUEL LEVEL	 FUEL FILTER	 LEADED FUEL	 UNLEADED FUEL
 BILGE BLOWER	 BILGE PUMP	 OIL	 ELAPSED TIME	 LIGHT	 INTERIOR LIGHT
 RUNNING LIGHTS UNDER POWER	 ANCHOR LIGHT	 FRESH WATER BASED COOLANT	 WASTE WATER/SEWAGE	 WINDSHIELD WIPER	 WINDSHIELD WASHER
 WINDSHIELD WIPER AND WASHER	 COMPASS	 ANCHOR	 HORN	 PROPULSION SYSTEM TRIM	 PROPULSION SYSTEM TRIM BOW UP
 PROPULSION SYSTEM TRIM BOW DOWN	 TRIM TAB TRIMMING OPERATION	 SINGLE LEVER CONTROL (THROTTLE & SHIFT)	 CONTROL LEVER OPERATING DIRECTION	 ROTARY CONTROL (QUANTITY INCREASES WITH WIDTH OF SYMBOL)	 BATTERY
 WARNING ELECTRICAL HAZARD	 FIRE RISK	 NO OPEN FLAME NO SMOKING	 PROPELLER	 LIFT POINT OR PROPER LOCATION OF SLING	 LIFT POINT



22. WARNING LABEL LOCATIONS

WARNING LABEL LOCATIONS (Fig. 1.17.1)

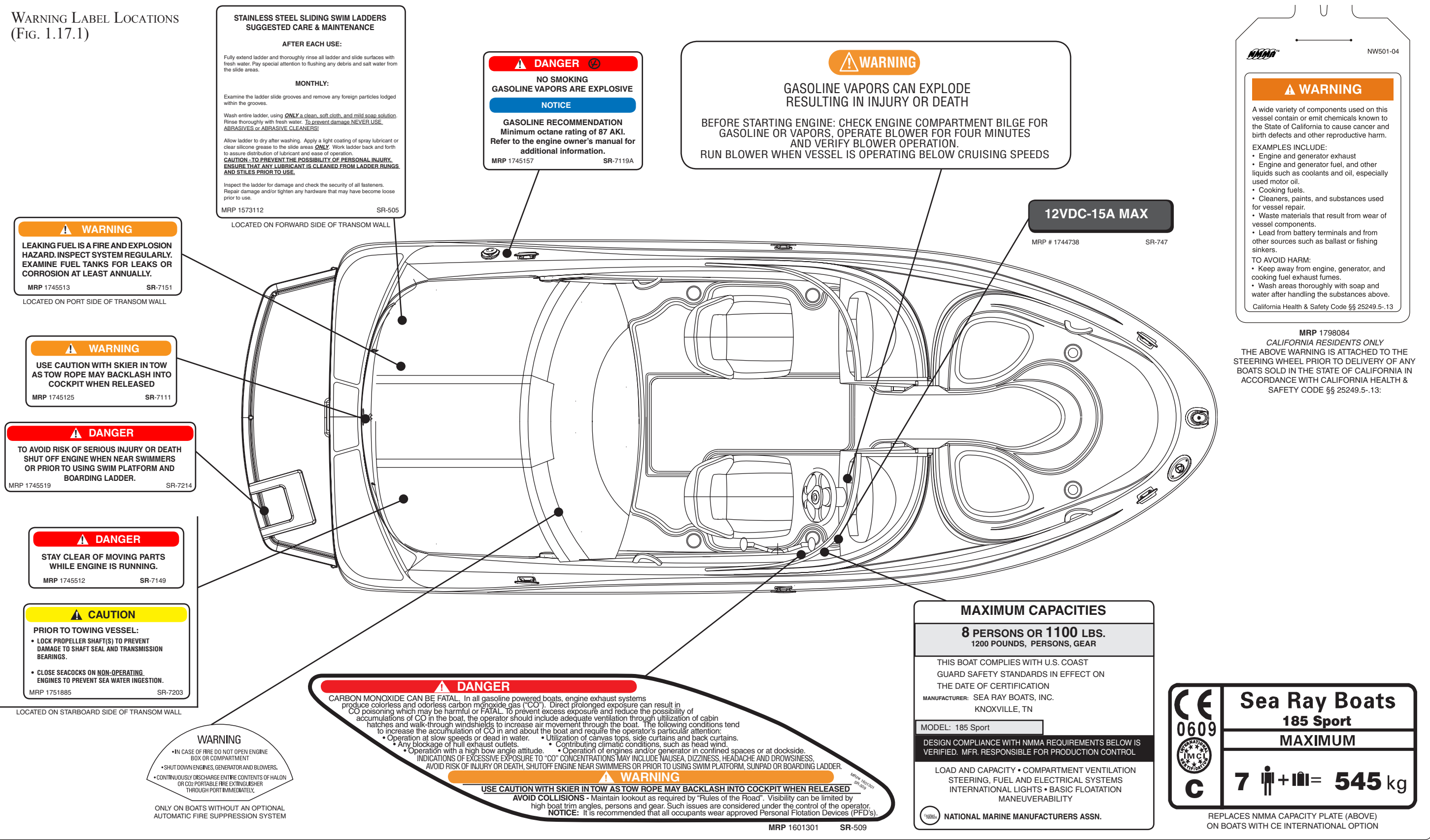

THIS PAGE LEFT INTENTIONALLY BLANK



SECTION 2 • GENERAL BOAT ARRANGEMENT

1. DOCKING/LIFTING/STORAGE

BOW AND STERN EYES: The bow eye must be used to haul the boat onto a trailer. The stern eyes must be used as tie down points for trailering the boat. The bow and stern eyes may be used for short term lifting of the boat such as for service. Long term lifting with the bow and stern eyes may cause stress on the fiberglass and gel coat.

For long term storage, use flat, wide belt-type slings and spreaders long enough to keep pressure from gunwales. With fiberglass boats, severe gelcoat crazing or more serious hull damage can occur during launching and hauling if pressure is created on the gunwales by the slings. Cable-type slings should be avoided. Do not place the slings where they may lift on underwater fittings.

When lifting the boat always keep the bow higher than the stern to drain the exhaust lines and to

prevent water from running forward through the manifold and into the engine where it can become trapped. It may seem expedient to lift only the stern when changing a propeller, but this can result in water entering the engine cylinders, causing hydrostatic lock and resulting in possible engine failure. Even a small amount of water in the engine can cause rust and is to be avoided.

Never hoist the boat with an appreciable amount of water in the bilge. Fuel and water tanks should preferably be empty, especially if of large capacity.

BOW AND STERN CLEATS: Cleats must not be used for lifting the boat; they are intended for docking or mooring use only.

CAUTION

Do Not use cleats for lifting.

CLEAT / BOW & STERN EYE LOCATIONS
(FIG. 2.1.1)

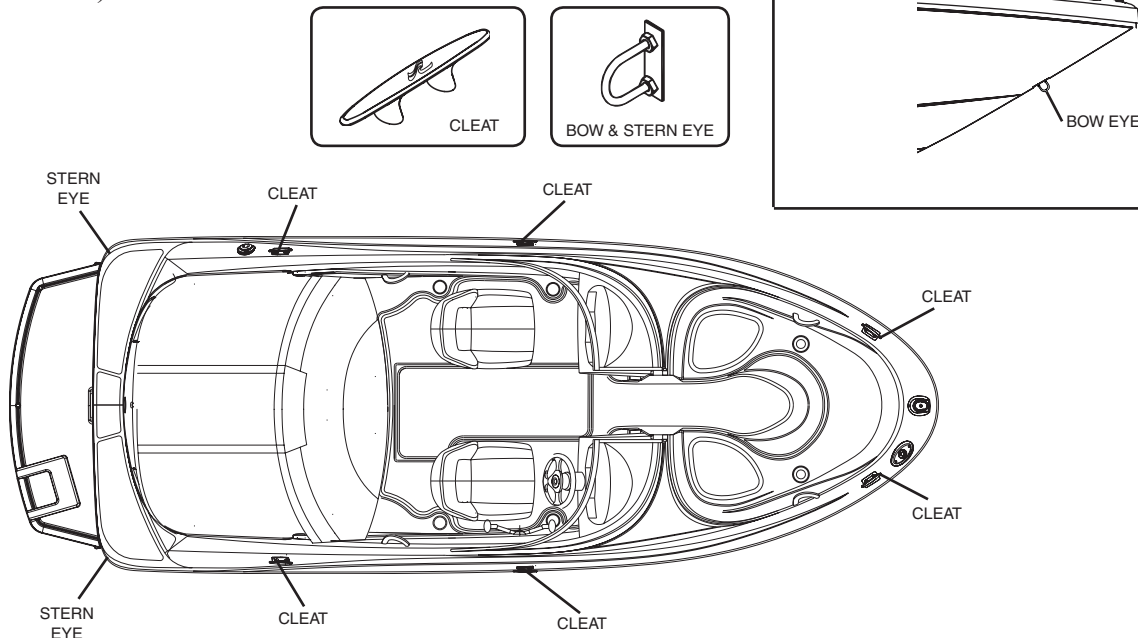

SECTION 2 • GENERAL BOAT ARRANGEMENT

2. PASSENGER LOCATIONS

! WARNING

Boat motion can be erratic.

You can fall overboard or be injured by hitting something in or on the boat.

All persons must be in cockpit area or cabin and be prepared for sudden boat movement.

Use front or bow deck area only during anchoring, mooring or emergencies.

1. When the boat is moving, all passengers must be in the cockpit area and must be on seating provided or, if standing, holding on firmly (Fig. 2.2.1).

While the person at the wheel must alert passengers before any sudden or erratic boat movement, such as crossing wakes, rapid turns, sudden acceleration or deceleration, etc., an emergency action may be necessary before

passengers can be warned. All passengers must be prepared for rapid boat movement and be able to hold on to prevent loss of balance.

2. When persons are on the working deck area, for anchoring, mooring or in emergencies, they must be holding on and be positioned so as to prevent falling. In bad weather and/or rough water, if it is essential to be on deck, persons should be closely tied to cleats, railing stanchions or other securely fastened boat hardware.
3. Engines must be turned off if the boat is near swimmers or persons are on the swim platform or the swim ladder.

! WARNING

Wet decks are slippery.

You can be seriously injured if you slip and fall.

Wear slip resistant footwear secured to your feet and hold on to rails or boat structure.

PASSENGER LOCATIONS
(FIG. 2.2.1)

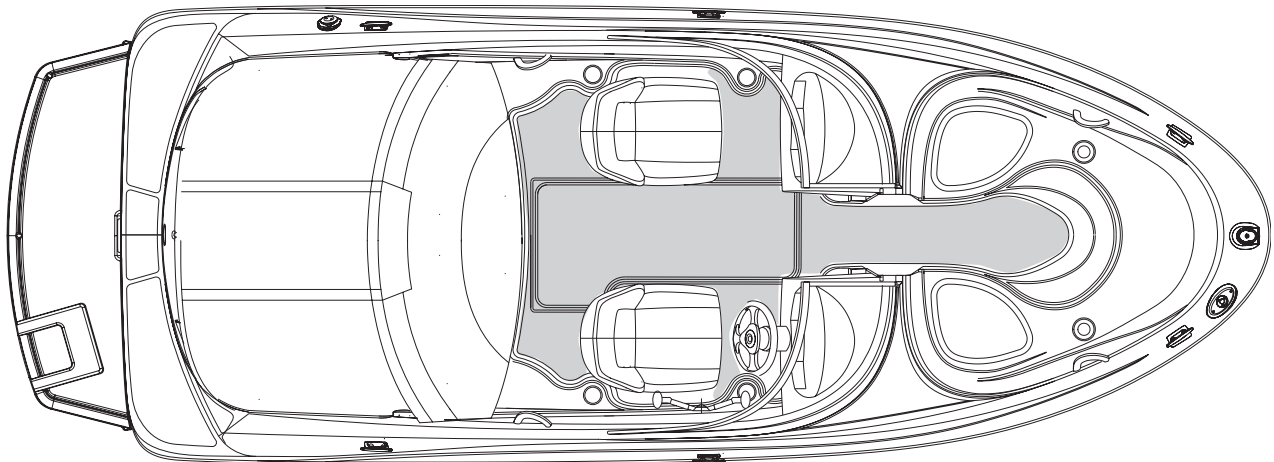

■ ACCOMMODATION DECK
(DECK AREA INTENDED FOR
OCCUPATION DURING NORMAL
OPERATION)

! DANGER

Rotating propellers can injure or kill you.

Shut off engine when persons are in water near boat, or on swim platform or ladder.

! WARNING

Wet decks are slippery.

You can be seriously injured if you slip and fall.

Wear slip resistant footwear secured to your feet and hold on to rails or boat structure.



SECTION 2 • GENERAL BOAT ARRANGEMENT

3. BASIC BOAT DIMENSIONS AND CLEARANCES

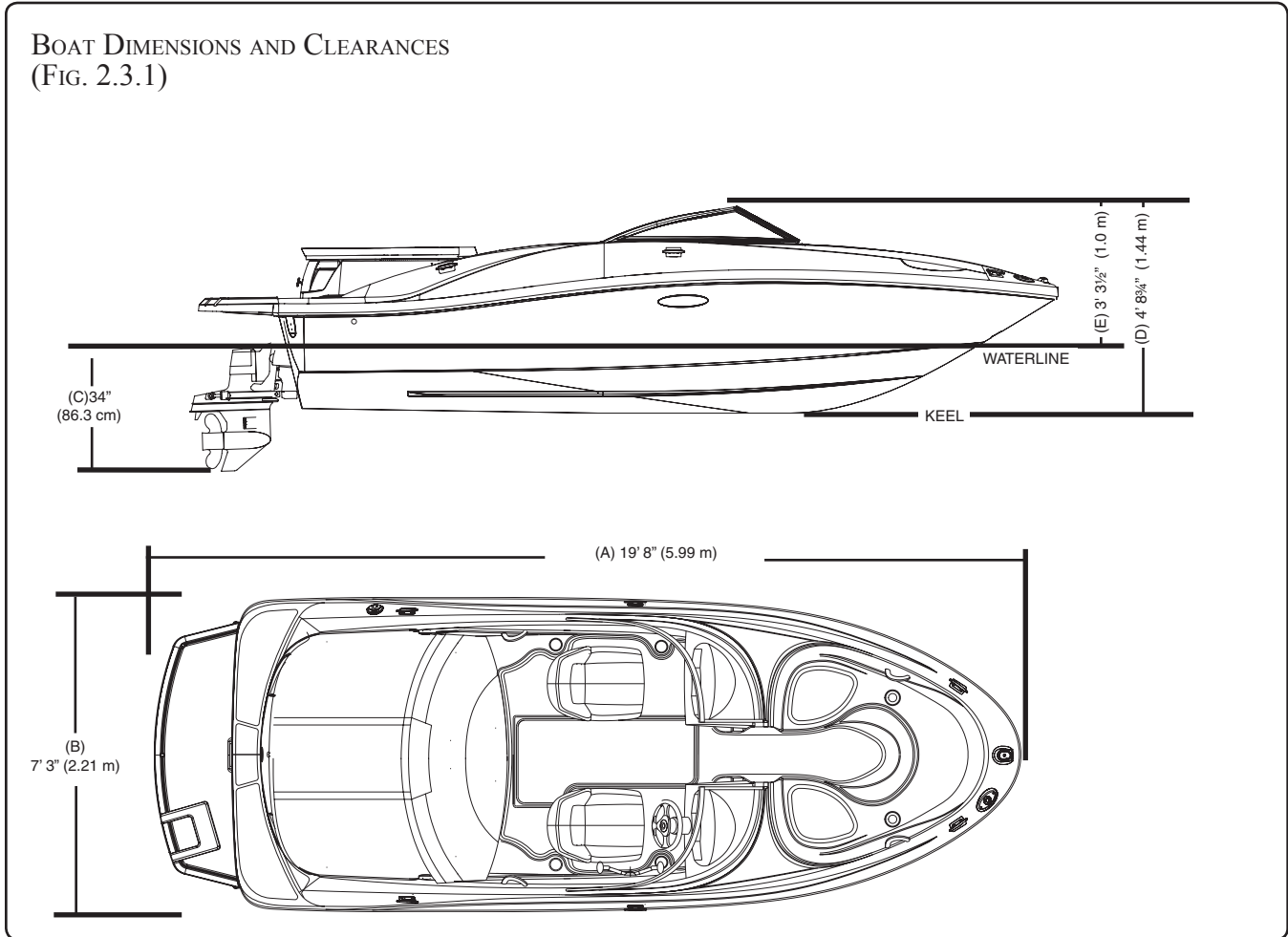

185 SPORT SPECIFICATIONS

(A) Overall Length		
With Std. Swim Platform.....	19ft. 8in.	5.99 m
(B) Beam (Width).....	7ft. 3in.	2.21 m
(C) Draft (Stern Drive Down)	34in.*	86.3 cm*
Draft (Stern Drive Up).....	17in.*	43.1 cm*

* MINIMUM WATER DEPTH TO PREVENT RUNNING AGROUND

Dry Weight.....	2,400 lbs.	1,088.6 kg.
Fuel Capacity.....	26 gal.	98.4 liters
Usable Fuel	24 gal.	90.8 liters
Dead Rise.....	19°	

HEIGHT DIMENSIONS

(D) Keel to Top of Windshield	4ft. 8 ³ / ₄ in.	1.44 m
(E) Waterline to Top of Windshield.....	3ft. 3 ¹ / ₂ in.	1.00 m



SECTION 2 • GENERAL BOAT ARRANGEMENT

4. DECK LAYOUT

GENERAL LAYOUT
(FIG. 2.4.1)

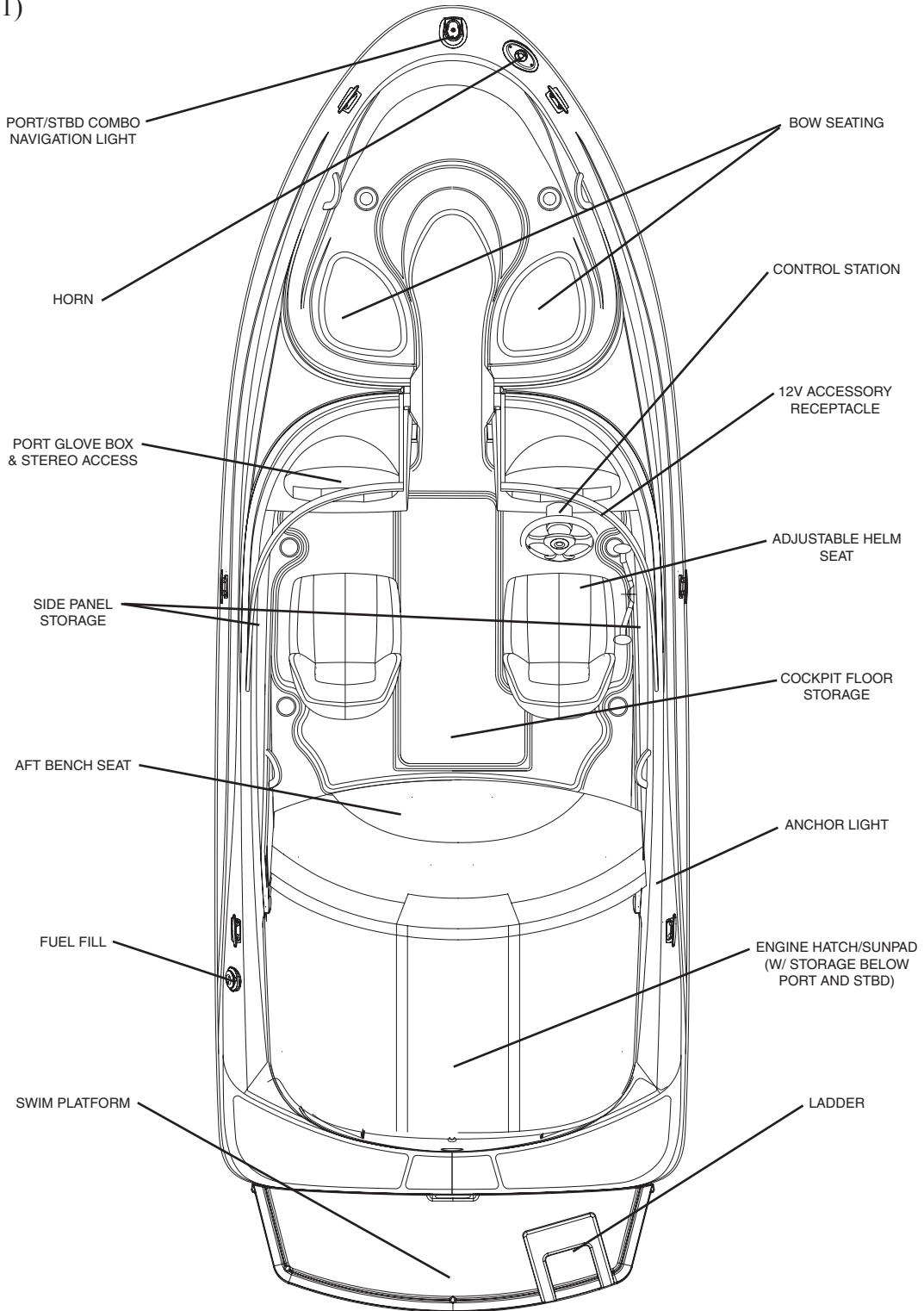

SECTION 2 • GENERAL BOAT ARRANGEMENT

5. HELM, GAUGE & SWITCH LAYOUT

HELM (FIG. 2.5.1)

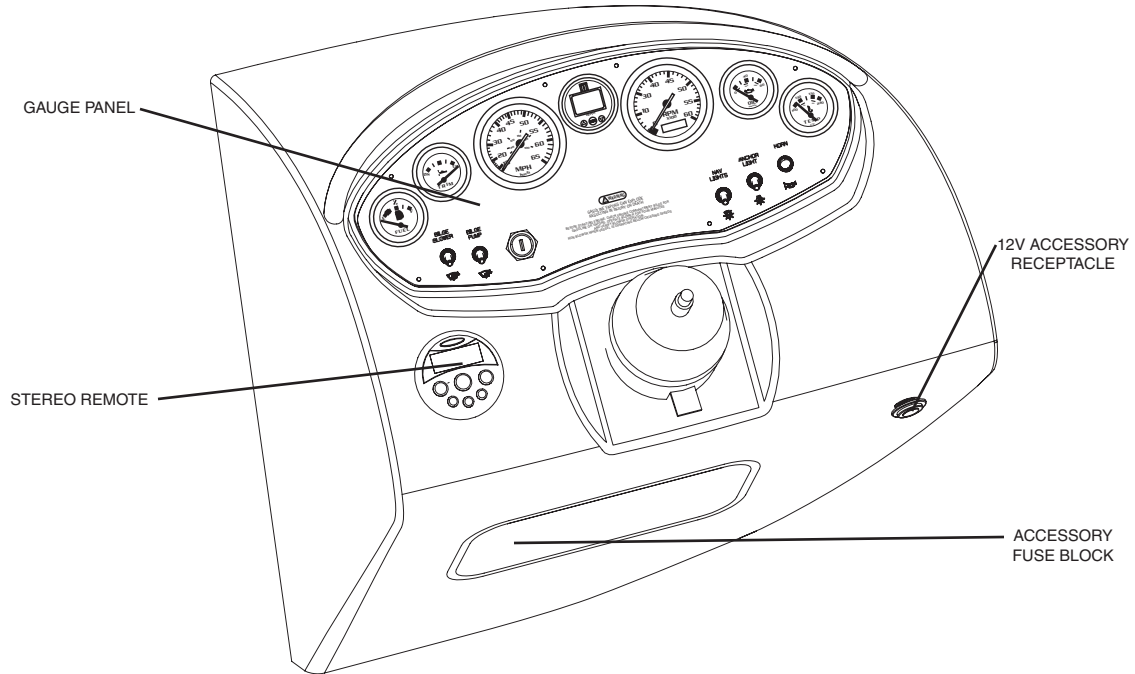

GAUGE PANEL (FIG. 2.5.2)

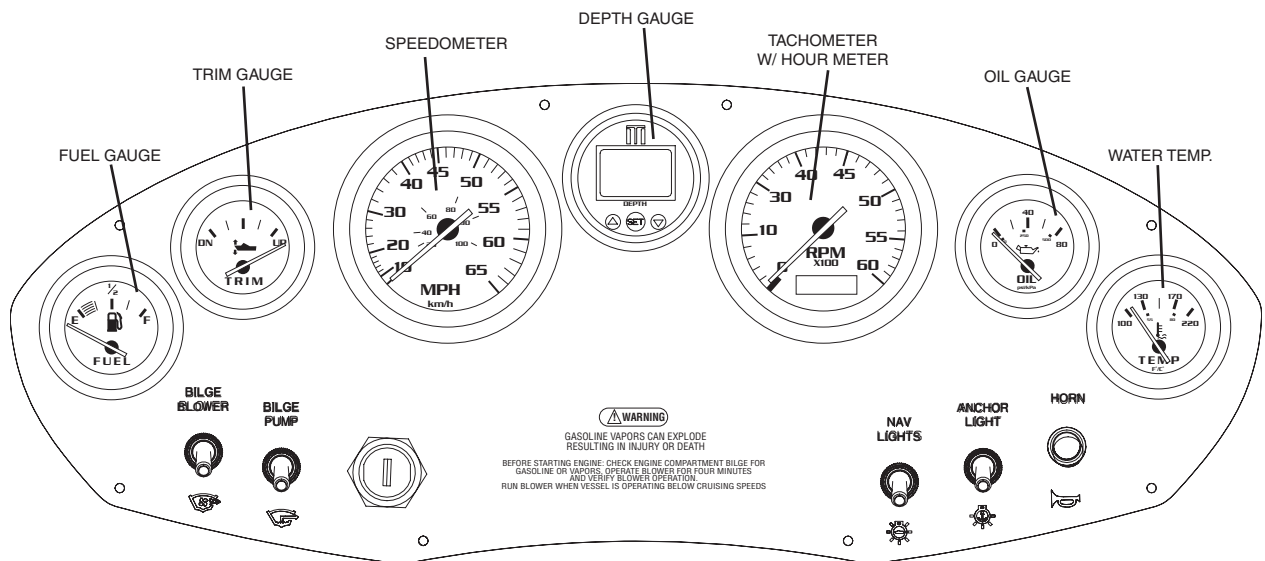

SECTION 2 • GENERAL BOAT ARRANGEMENT

6. FUNCTION AND LOCATION OF THROUGH-HULL CUTOUTS

STARBOARD THROUGH-HULL CUTOUTS
(FIG. 2.6.1)

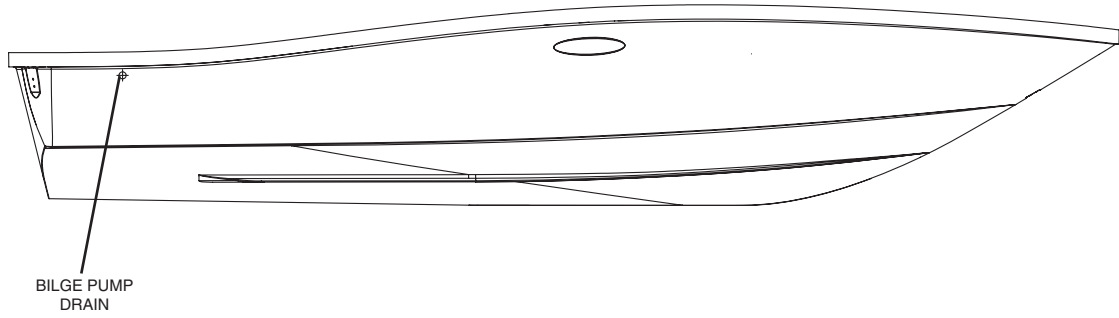

BILGE THROUGH-HULL CUTOUTS
(FIG. 2.6.2)

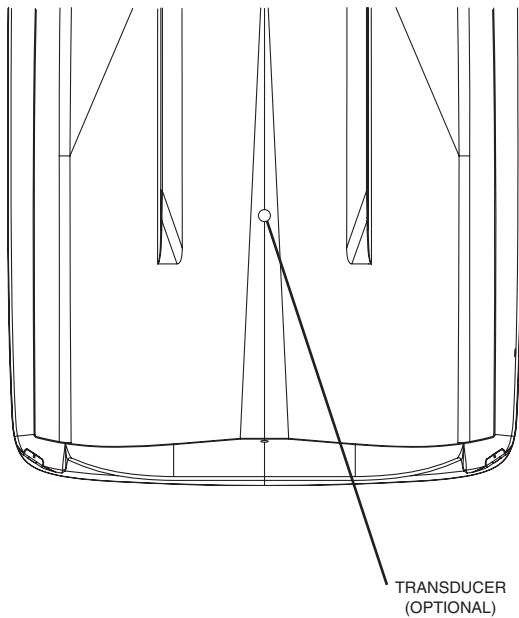

TRANSOM THROUGH-HULL CUTOUTS
(FIG. 2.6.3)

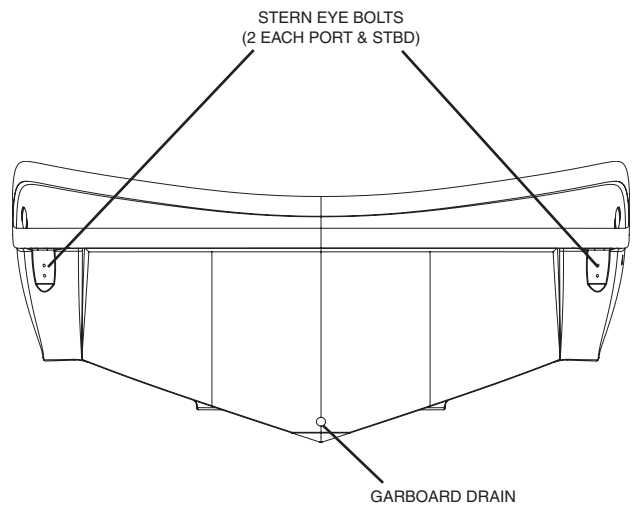

SECTION 2 • GENERAL BOAT ARRANGEMENT

7. PROPULSION SYSTEM

The engine on your boat is a stern drive propulsion system also known as an inboard-outboard engine. This type of propulsion system has the engine inside the boat secured to the hull's stringers at the rear end of the hull. The stern drive unit, also called the outdrive because it hangs below the hull, is part of the propulsion system that attaches to the outside of the hull or transom. The stern drive unit pivots to steer the boat.

REFER TO THE ENGINE OWNER'S MANUAL FOR OPERATING INSTRUCTIONS AND WARRANTY INFORMATION.

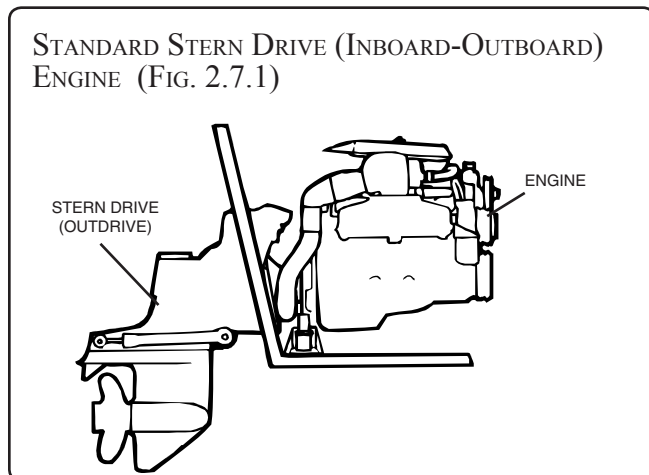

8. DESCRIPTION OF MAJOR CONTROLS

A. GEAR SHIFT AND THROTTLE CONTROL

The shift/throttle control unit for the engine activates by the shifting mechanism and the throttle. The control must be in the neutral position to start your engine. Moving the lever forward first engages the forward gear. Further forward movement increases engine speed and propeller RPM, moving the boat faster. To shift to reverse, bring the control lever back to the neutral position, then move it further back to engage the reverse gear. Further rearward movement of the lever increases engine speed and propeller RPM, moving the boat faster in reverse.

Shift/throttle controls are equipped with a “throttle only” mechanism which allows the shift mechanism

to be disengaged from the throttle. This allows the throttle to be advanced without shifting the transmission when starting. It may be necessary to use the “throttle only” button in order to pump fuel into the engine for ease in starting.

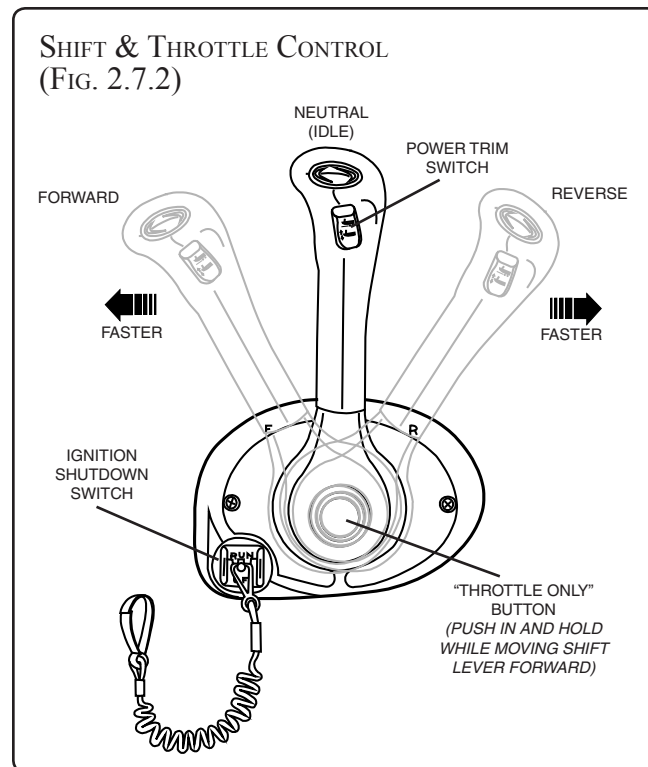

The “throttle only” mechanism may differ from one style gear/throttle unit to another. Refer to your Gear Shift & Throttle Manual for proper operation of this feature.

The throttle control adjusts the RPM of the engine and thus, the rotational speed of the propeller. Regulating the RPM of the engine controls the speed of the boat.

Forward motion creates forward moving water called a “following” wake. If the boat is moving forward and the shift/throttle is moved quickly from forward to reverse, the boat will stop rapidly and then move backward. The following wake continues to move forward and can rise above the transom and flood the boat.

Do not shift into reverse too quickly. Wait for the following wake to dissipate.



SECTION 2 • GENERAL BOAT ARRANGEMENT

⚠ CAUTION

Cockpit can fill with water if boat is moving forward, when it is put into reverse.

Before shifting into reverse, shift to neutral, wait for boat to stop moving forward, then shift into reverse.

B. POWER TRIM UNIT AND GAUGE

The power trim allows the operator to raise and lower the stern drive unit while underway to provide the ideal boat angle (in relation to water surface) for a given load and water condition (Fig. 2.8.1).

Trimming UP rotates the stern drive and propeller away from the transom. Trimming DOWN rotates the stern drive and propeller closer to the transom.

When the stern drive is trimmed DOWN, the bow of the boat is being forced down. If the trim is in the full DOWN position when accelerating from idle to plane, the boat will plane faster with less bow rise. Once on plane, the stern drive unit can be trimmed UP slightly. This will raise the bow of the boat slightly and increase speed. You will need to try small differences in the stern drive position to determine the trim position you prefer under various conditions.

If you raise the stern drive up too far while you are on plane, you could cause a loss of speed and power due to condition called propeller “ventilation.” If this happens, there will be a sudden increase in engine RPM and loss of speed. Do not let this condition exist. Immediately reduce your engine RPM and trim the outdrive DOWN slightly until engine slows down and you regain forward speed.

The trim gauge indicates the position of the stern drive relative to the transom.

REFER TO YOUR ENGINE OPERATOR'S MANUAL FOR PROPER TRIM GAUGE SETTING.

EFFECTS OF POWER TRIM (FIG. 2.8.1)

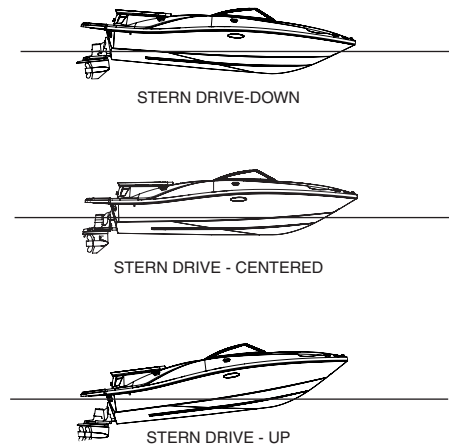

POWER TRIM SWITCHES (OPTIONAL) (FIG. 2.8.2)

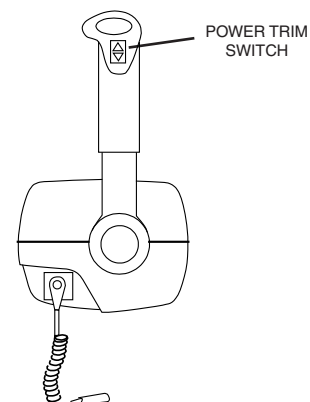

C. TRAILER SWITCH

The trailer switch (power trim switch) (Fig. 2.8.2) is not to be confused with the power trim function. The trailer switch is to be used only when the engine is OFF.

The trailer switch allows the drive unit to be raised for trailering, beaching and launching. To operate, press and hold the trailer switch until the drive unit reaches the end of upward travel. The mechanism that raises the lower unit will stop operating at the end of the upward travel. To bring the drive unit down into boating position, push the power trim switch down.

SECTION 2 • GENERAL BOAT ARRANGEMENT

D. ENGINE ALARM SYSTEM

⚠ CAUTION

Always check oil pressure and water gauges while moving, even if your engine has an alarm.

Shut down engine immediately if gauges are not in normal ranges, or alarm sounds.

Do not restart engine until problems are corrected.

The engine Operator's Manual will tell you if your engine is equipped with an audible alarm and how to use it.

The alarm indicates a problem with engine water temperature, oil pressure and/or stern drive oil level.

9. IMPORTANT GAUGES

A. TACHOMETER AND HOUR METER

TACHOMETER
(FIG. 2.9.1)

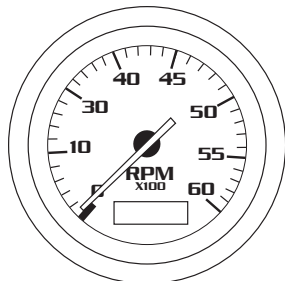

The tachometer indicates the revolutions per minute (RPM) of the engine. (It does not indicate the speed of the boat.) Your Engine Operator's Manual indicates the maximum full throttle RPM at which your engine should operate. This must not be exceeded or serious engine damage will occur. The tachometer should also be used to determine the most comfortable and economical cruising RPM.

The hourmeter measures the cumulative hours of operating time. The hourmeter should be used to keep a careful log of engine maintenance as well as performance data and fuel consumption. Do not leave ignition key ON with the engines off, as this will increase the engine hours on the hourmeter.

B. OIL PRESSURE, WATER TEMPERATURE, SPEEDOMETER AND FUEL GAUGES

These gauges function on your boat the same way they do on your car or truck. You must continually check these gauges visually to make certain there are no engine system problems even if your boat engine has an alarm system.

C. MAGNETIC COMPASS

Your compass, properly corrected, will indicate magnetic north (not true north). A compass must be adjusted by a qualified person. The reason for this is that nearby instruments or objects containing magnets or current-carrying electrical wires will influence the compass reading. This is especially true if you add electronic devices to the helm station.

MAGNETIC COMPASS
(FIG. 2.9.2)

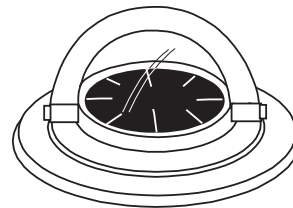

After your compass has been professionally adjusted. You will be given a deviation card or chart indicating the correction to be applied when laying out a compass course or making navigational calculations. **Keep this correction card or chart at the helm.**

NOTE: The compass adjustment is only good for the equipment arrangement that existed at the time of the adjustment. If you place different equipment or remove equipment from the vicinity of the compass, you cannot rely on the compass reading. The compass must be readjusted by a qualified person after equipment is added or removed from the vicinity of the compass.

NOTE: The compass roses shown on navigational charts have both true north and magnetic north directions superimposed. Make certain you plot course compass directions from the magnetic north compass rose.



SECTION 2 • GENERAL BOAT ARRANGEMENT

When not in use, the compass should be protected from excessive and prolonged sunlight. If your compass becomes sluggish or erratic, it should be serviced by an authorized repair station.

To keep the plexiglass dome free from scratches, remove salt deposits and dust with a damp cloth. An occasional treatment with paste wax will help preserve the dome surface.

REFER TO OWNER'S MANUAL PACKET FOR INSTRUCTIONS AND WARRANTY INFORMATION.

10. NAVIGATION AND ANCHOR LIGHTS

Navigation lights (Fig. 2.10.2) **MUST** be on while underway from sunset to sunrise or in conditions of reduced visibility. "Underway" means the boat is not docked or at anchor. Trolling or drifting with engine off is considered "underway" and navigation lights must be used.

If you are anchored in open water, i.e. where other boats can approach yours, you must display your anchor light (Fig. 2.10.1): a white light that can be seen from all possible directions, i.e. 360 degrees.

Read the "Federal Requirements and Safety Tips for Recreational Boats" provided in your kit.

NAVIGATION LIGHTS
(FIG. 2.10.2)

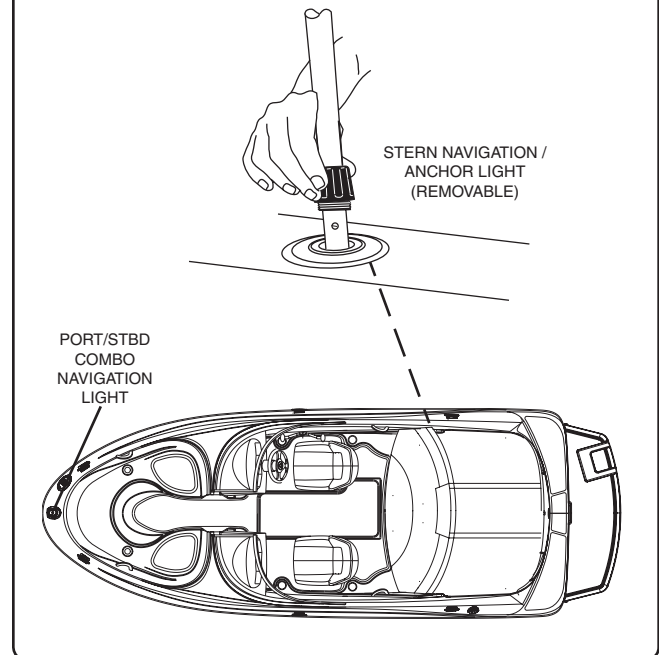

NAVIGATION AND ANCHOR LIGHT SWITCHES
(STBD HELM SWITCH PANEL) (FIG. 2.10.1)

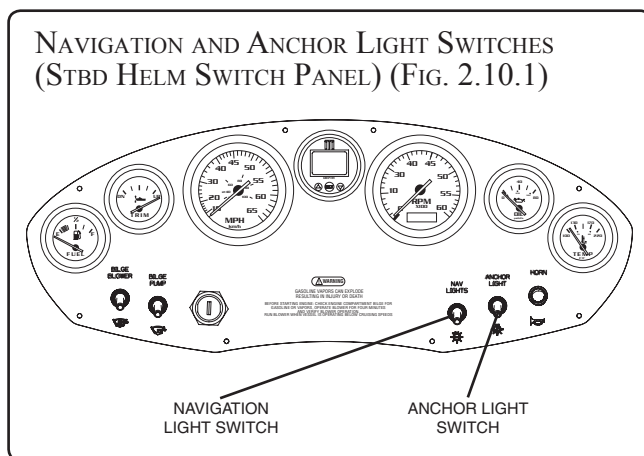

SECTION 3 • USING YOUR BOAT

1. PRE-LAUNCH, LAUNCH AND POST-LAUNCH CHECKLIST

Listed below are the critical items you must check and do each time you use your boat. It does not list all of the necessary maintenance and service items required to keep your boat running properly. These other items are found in Section 8.

BEFORE LAUNCH

- Drain plug installed
- Enough fuel for trip
- Float plan given to friend or relative
- Navigation charts for trip
- Weather forecast - safe

IN THE WATER, BEFORE BOARDING PASSENGERS OR STARTING ENGINE

- Equipment stored and balanced
- No gas smell in engine compartment
- Engine oil and steering fluid levels - OK
- Bilge pump working
- Bilge blower on
- Radio and navigation equipment functioning

PASSENGERS

- Wearing PFDs
- Seated properly
- Given safety instructions

STARTING ENGINE

- Make sure you have read and understand the dangers of Carbon Monoxide (CO) information in this manual.
- Bilge blower on for at least four (4) minutes. Feel to confirm airflow at hull vent on transom. Inspect bilge area for visual and odor confirmation that there are no fuel leaks.

- Gear shift in neutral position. Throttle pumped before starting, if necessary.
- Oil pressure, engine temperature, voltage - OK after starting and warm up.

UNDERWAY

- Gradual acceleration and deceleration and turning.
- Aware of surroundings at all times.
- Operate so as to prevent buildup of Carbon Monoxide (CO)
- Monitor weather
- Use navigational aids in water and on shore
- Keep passengers safe
- Check fuel consumption regularly
- Check all gauges frequently

END OF TRIP

- Equipment dry and stored.
- Electronic equipment and switches off.
- Notify person who had float plan.
- Boat covered properly for trailering, docking or mooring.
- If boat is pulled from water, drain plug removed.
- If boat is pulled from water, hull and propeller inspected for damage.

WARNING

An improper trailer can cause structural damage to the hull.

A damaged hull can be unsafe; it could cause the boat to sink.

Use a trailer that can properly support the boat's weight and shape. Get professional help in picking the right trailer for your boat.



SECTION 3 • USING YOUR BOAT

2. FUELING THE BOAT

! DANGER

NO SMOKING

GASOLINE VAPORS ARE EXPLOSIVE

NOTICE

GASOLINE RECOMMENDATIONS

Minimum octane rating of 87 AKI.

Refer to the engine owner's manual
for additional information

! DANGER

Gasoline vapors can explode from static electricity if fueling is not done properly.

Read and understand this section and
Section 5 • Fuel System

The fuel fill cap is located on the port aft deck (Fig. 3.2.1).

Refer to your engine manual for the proper grade of gasoline.

BEFORE FUELING

- Fuel during daylight hours.
- Tie boat to the dock.
- Shut off engine, bilge blower and all other electrical equipment.
- Shut off gas burning appliances (gas stove, etc.).
- Close all hatches, doors and keep engine compartment closed to prevent gasoline fumes from entering the cockpit area.
- All passengers must leave the boat, as a precaution.
- There must be no smoking or any flames within 20 feet of the boat, before, during and for at least 5 minutes after fueling is completed.

FUEL FILL LOCATION
(FIG. 3.2.1)

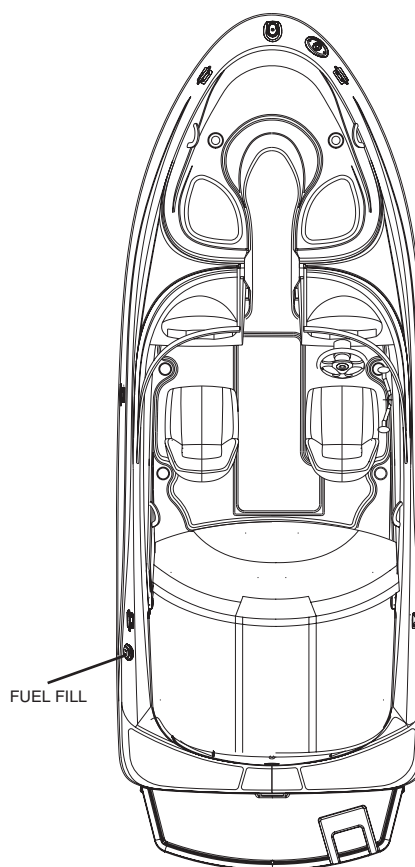

- Open fuel fill cap and insert hose nozzle into the fuel fill opening. Fuel fill hose nozzle must contact the fuel fill opening **BEFORE** adding fuel and throughout the fueling process to prevent discharge of static electricity.

FILLING THE TANKS

- Check the fill plate label to ensure that fuel is placed **ONLY** in the fuel tank. The fuel fill plate is located on the port aft deck (Fig. 3.2.1).
- Keep nozzle in contact with fuel fill opening at all times during fueling.
- Listen as tank fills and stop adding fuel before it spills. Fuel must have room for expansion.



SECTION 3 • USING YOUR BOAT

AFTER FILLING

- DO NOT wash spilled fuel overboard. Wipe up any spill with rags or paper towels and dispose of them properly on shore.
- Open engine compartment and check for fuel fumes. This is especially important if your boat is equipped with a gasoline engine. Leave compartment open until no odor is apparent. Close compartment.
- If fumes in the engine compartment do not disappear, do not turn on blower or start engine. Get help from trained and experienced persons before using the boat.
- Turn on blower for four minutes, then restart engine.
- Assist passengers back into the boat.

3. BOARDING

**WARNING**

Wet decks are slippery.

You can be seriously injured if you slip and fall.

Wear slip-resistant footwear secured to your feet and hold onto rails or boat structure.

- DO NOT overload the boat.
- Board one person at a time and give assistance as needed.
- Transfer gear and equipment by handing it from a person on the dock to a person on board. You can lose your balance and be injured if you attempt to board while carrying equipment or gear.
- Distribute the weight of equipment and passengers as evenly as possible to keep the boat balanced.
- Stow gear and equipment so that it is accessible, but everything is to be stored in places to prevent it from shifting if the boat encounters rough water or weather.

4. PERSONAL FLOTATION DEVICES (PFDs)

- Operator must instruct all passengers on location and use of PFDs (See page 1.4 for type and usage).
- Children less than sixteen (16) years of age and all nonswimmers, adults as well as children, must wear properly-sized PFDs at all times when aboard.
- ALL passengers should wear PFDs. By the time someone falls overboard, it can be too late for them to put on a PFD and fasten it properly. This is especially true in colder waters, below 70°F, where survival time, before hypothermia sets in, is measured in minutes.
- If there are passengers not wearing PFDs, the PFDs must be readily accessible. “Readily accessible” means out of the storage bag and unbuckled.
- All throwable flotation devices (cushions, rings, etc.) must be right at hand.

5. PASSENGER INSTRUCTION AND LOCATION

- Everyone on board must be told about the boat’s behavior from starting to getting up on plane.
- Before the operator does any high-speed maneuvers or rapidly accelerates or decelerates the boat, passengers must be warned to sit and hold on and must heed the warning.
- The operator may have to make rapid changes in speed and/or direction to avoid a problem, with little or no time for alerting passengers. It is critical that all passengers be seated in the designated seating areas and holding on at all times to prevent falling overboard or getting knocked about in the boat when underway.
- If standing, maintain a firm grip on handholds. When walking, grasp handholds.



SECTION 3 • USING YOUR BOAT

6. STARTING THE ENGINE

DANGER

Gasoline vapors can explode

Before starting the engines, open engine compartment and check for gasoline smell.

- **If you smell gasoline, do not start engine; get everyone off the boat and get trained help to find and fix the problem.**

If there is no gasoline smell, perform checks specified by manual, then and only then, close engine compartment and run blower for at least 4 minutes before starting.

The engine operation and maintenance manual furnished with your boat describes pre-start and starting procedures. We urge you to thoroughly read and understand your engine manual.

Listed below are basic pre-start and starting reminders. These are not a substitute for the engine manufacturer's specific recommendations.

Open the engine compartment and check for the smell of gasoline.

- IF YOU SMELL GASOLINE, get everyone off the boat, do not operate any electrical switches or light any matches, lighters, etc. Get trained help to find and fix the problem before starting the engine or operating any switches on the boat.

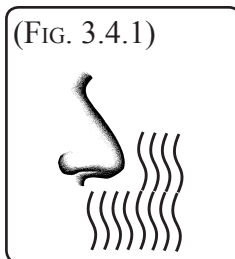

- If you DO NOT smell gasoline...

1. Check all fluid levels and any other necessary checks as specified in Section 8 and in the engine manual.

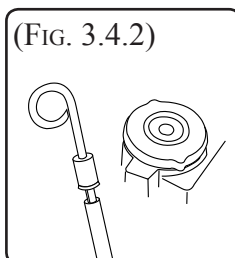

2. Check that water level in bilge is minimal. Verify that the bilge pump is operating by turning the bilge pump switch to MANUAL and listening for the pump running and check to see that bilge water is being pumped overboard.

3. Check fuel level. Be sure you have enough fuel for your trip. Remember the "Rule of Thirds": Use no more than 1/3 of your fuel for outbound trip; use 1/3 of the fuel for return trip; keep 1/3 for reserve in case of emergency.

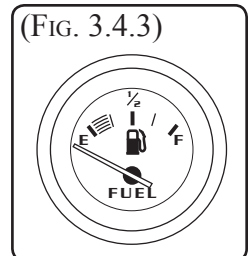

4. Run bilge blowers for at least 4 minutes before attempting to start engine

Unlike your automobile engine which is naturally ventilated even when it is not moving, your boat engine compartment (the bilge) does not have sufficient natural ventilation when the boat is not moving or moving slowly. That is why the engine compartment must have forced ventilation, using the bilge blower, to remove potentially explosive gasoline vapors, before the engine is started and when the boat is moving slowly.

Because it may be difficult to remember to turn on the bilge blower every time you slow down the boat, it is recommended that the bilge blower run all the time when the engines are running.

5. Place drive unit in full DOWN/IN position.

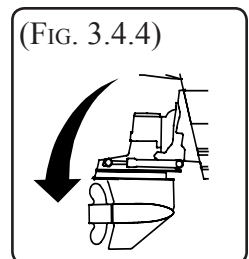

6. Put throttle and shift control lever into neutral; then for a:

COLD ENGINE - Press **THROTTLE ONLY** button and move shift/throttle lever forward to full open throttle, then return to

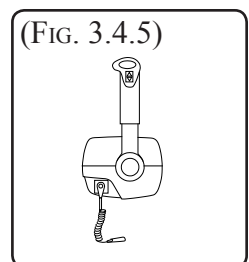

SECTION 3 • USING YOUR BOAT

about 1/4 throttle. In cold weather, it may be necessary to pump lever several times before engine will start.

WARM ENGINE - Press **THROTTLE ONLY** button and move shift/throttle lever about 1/4 open throttle position. Do not pump lever.

FLOODED ENGINE - Press **THROTTLE ONLY** button and move shift/throttle lever to full open position. **DO NOT** pump lever. When the engine starts, move shift/throttle lever back rapidly to decrease engine speed to between 1000 and 1500 RPM.

7. TO START ENGINE:

Turn ignition key clockwise, as in a car, and release when engine starts. Do not crank engine for more than a few seconds if it doesn't start. Engine may be very cold or flooded; see step 6.

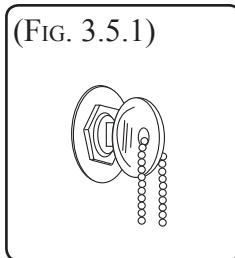

8. After engine starts, reduce speed to between 1000 and 1500 RPM and check oil pressure.

9. If oil pressure is correct, let engine warm up to normal temperature range as specified in the engine manual, before shifting into forward or reverse gear.

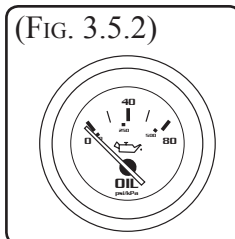

IF OIL PRESSURE GOES ABOVE OR BELOW OPERATING RANGE SHUT DOWN THE ENGINE IMMEDIATELY. GET TRAINED HELP TO FIND AND FIX THE PROBLEM.

11. Check water temperature to ensure temperature range remains normal.

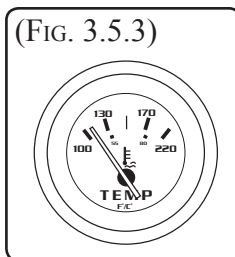

IF ENGINE TEMPERATURE GOES ABOVE NORMAL RANGE SHUT DOWN THE ENGINE IMMEDIATELY. GET TRAINED HELP TO FIND AND FIX THE PROBLEM.

7. SHIFTING TO DRIVE THE BOAT

CAUTION

Cockpit can fill with water if boat is moving forward, when it is put into reverse.

Before shifting into reverse, shift to neutral, wait for the boat to stop moving forward, then shift into reverse.

Bring the shift/throttle lever back to neutral position. The **THROTTLE ONLY** button will pop out.

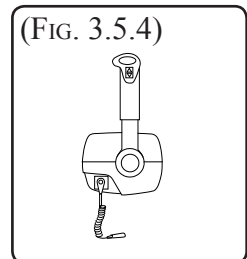

Then move shift/throttle lever rapidly, either forward or reverse, but not very far from the neutral position. The drive unit will engage and boat will start to move slowly in either forward or reverse. You can damage the transmission if you do not shift quickly from neutral into gear. Once clear of the dock, mooring, people and/or the no-wake zone and the boat has been shifted into forward gear, move shift/throttle lever forward to desired engine speed.

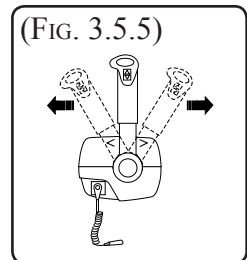

SECTION 3 • USING YOUR BOAT

8. STOPPING THE ENGINE

1. Move the shift/throttle lever to **NEUTRAL** and let engine idle for about 5 minutes to allow engine to cool down.

(FIG. 3.6.1)



2. Turn OFF ignition key.

(FIG. 3.6.2)



SHIFT, THROTTLE & STEERING CABLE ROUTING
(FIG. 3.6.3)

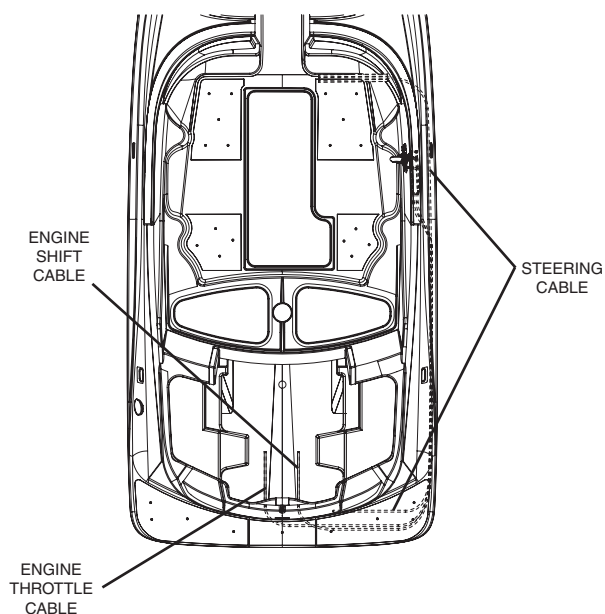

9. STEERING SYSTEM

! WARNING

Failure of the steering system will cause loss of control of your boat. Any change in steering such as looseness, tightness, binding, etc., must be checked immediately by your Sea Ray dealer.

The steering system is an enclosed push-pull cable that is hydraulically assisted (power steering) at the stern drive end (Fig. 3.6.3 & 3.6.4). THE CABLE AND ITS CONNECTIONS TO THE STEERING WHEEL AND TO THE OUT DRIVE MUST BE INSPECTED AT LEAST TWICE A YEAR BY YOUR SEA RAY DEALER. See Section 8 of this manual for inspection, service and maintenance recommendations.

The power steering pump (Fig. 3.6.4) fluid level MUST be checked every time prior to using the boat. Refer to the steering system information in your Owner's Packet.

POWER STEERING SYSTEM
(FIG. 3.6.4)

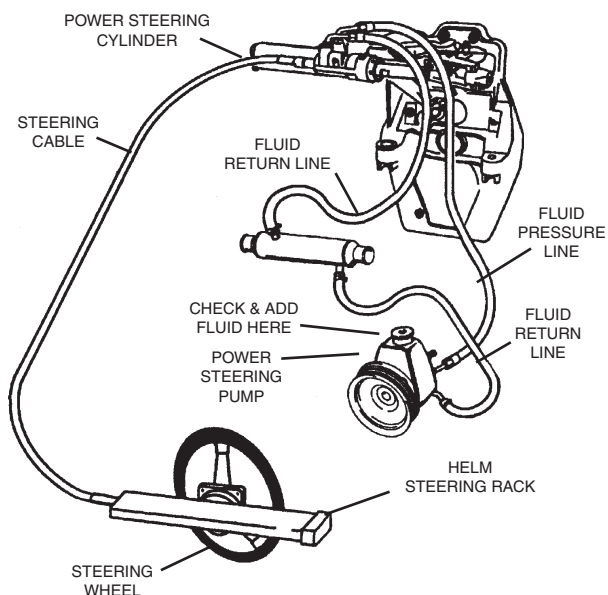

SECTION 4 • BILGE & UNDERWATER GEAR

1. BILGE

A. FUEL AND OIL SPILLAGE

Regulations prohibit discharging fuel or oily waste in navigable waters. Discharge is defined as any action which causes a film, sheen or discoloration on the water surface, or causes a sludge or emulsion beneath the water surface. A common violation is bilge discharge. Use rags or sponges to soak up fuel or oily waste, then dispose of them properly ashore. If there is much fuel or oil in the bilge, contact a knowledgeable marine service to remove it. Never pump contaminated bilge water overboard.

Fill fuel tank to less than rated capacity. Allow for fuel expansion.

B. DRAIN PLUG

! DANGER

Install and tighten drain plug before launching boat.

Boat will sink if drain plug is not in place and tight.

The bottom of the engine compartment is called the “bilge”. It is the lowest and inner part of the hull. Water and other liquids will collect there.

After removing your boat from the water, unthread the drain plug to drain the bilge (Fig. 4.1.1).

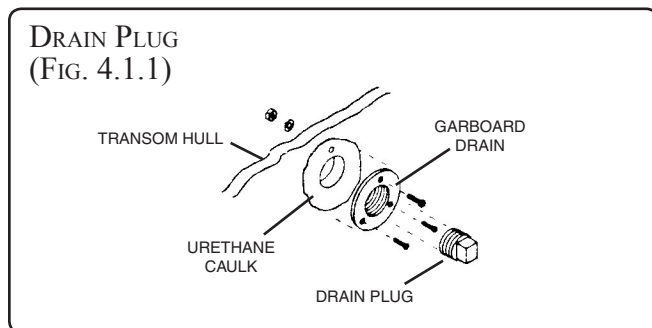

C. BILGE PUMP

! WARNING

SINKING HAZARD – Ensure the bilge pumps are operating properly.

! CAUTION

Run bilge pumps in the manual position only as long as necessary to remove water. Running bilge pumps dry can damage the pump motor.

A bilge pump and float switch are located in the bottom of the bilge (see Fig. 4.7.1). The bilge pump can be manually activated from the switch located on the Switch Panel at the helm.

Before starting the engine, push up on the bilge pump switch so that the switch light comes ON. Make sure the pump is working by opening the engine compartment, listening to hear the pump running and checking to see that liquid is being pumped out from the bilge pump through hull discharge (See Fig. 2.6.1). If the bilge has more liquid than normal, see Maintenance Section for locating and correcting the problem.

Except for checking the operation of the bilge pump by using the ON position, leave the switch in the OFF (AUTO) position. In the OFF (AUTO) position, when the bilge liquid is deep enough to activate the float switch, the bilge pump turns on and pumps out the bilge liquid until the float switch drops and shuts off the pump.

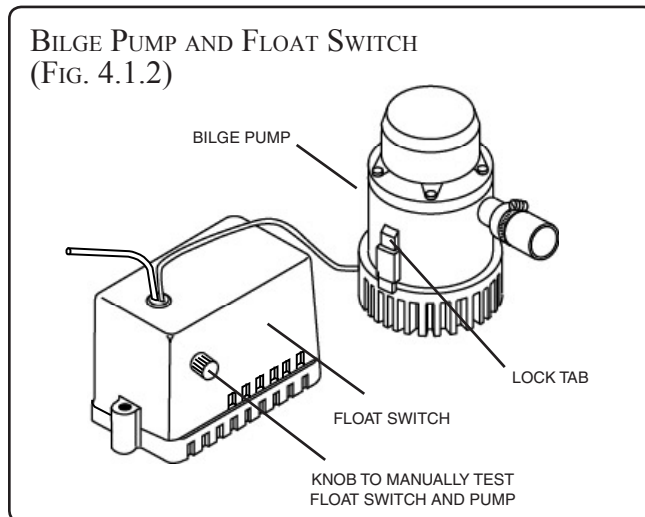

SECTION 4 • BILGE & UNDERWATER GEAR

If the liquid level in the bilge is higher than normal and the bilge pump empties the bilge when you use the ON switch, either the breaker for the automatic bilge pump circuit has blown or the float switch is not operating properly. Have it checked immediately. If the ON switch does not operate the pump, DO NOT use the boat until the problem is corrected.

The bilge pump automatic circuit is protected by a fuse in the engine compartment (see Fig. 4.2.1). The bilge pump manual circuit is protected by a fuse in the accessory fuse block located at the helm (see Fig. 6.4.1).

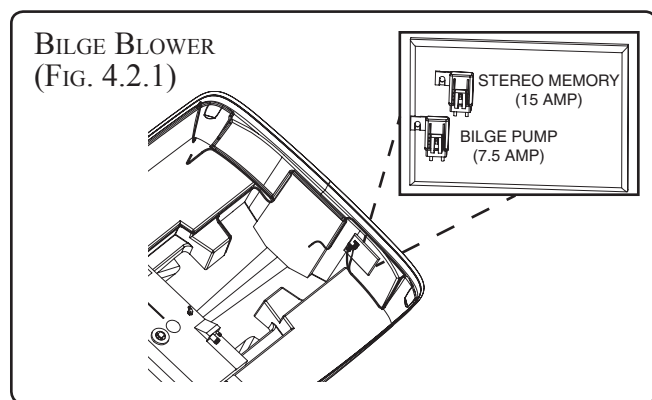

1. MAINTENANCE

Frequently inspect the area under the float switch to ensure it is free from debris and gummy bilge oil. To clean, soak in heavy duty bilge cleaner for 10 minutes, agitating several times. Check for unrestricted operation of the float. Repeat the cleaning procedure if necessary.

Inspect the bilge pump intake and keep it free of dirt or material which may impede the flow of water through the pump. To clean the pump strainer, depress the lock tabs on both sides of the pump and lift the pump motor.

TROUBLESHOOTING:

If water does not come out of discharge hose:

1. Check the "BILGE PUMP" fuse in the engine compartment (see Fig. 4.2.1) to ensure it has not blown.

2. Remove the motor module to see if the impeller rotates with the power on.
3. Remove any debris that may have accumulated in the nozzle section or strainer base.
4. Check hose and connection on hull side for debris and proper connections.

D. BILGE BLOWER

To prevent buildup of gasoline fumes to the explosive level in the engine compartment, the bilge blower must be run for at least four (4) minutes before starting the engine and kept running at all times when the engine is running to ensure that there will be adequate ventilation when you are moving slowly.

! WARNING

Do not allow obstructions to interfere with bilge blower or ventilation intake operation. Engine performance may be adversely affected.

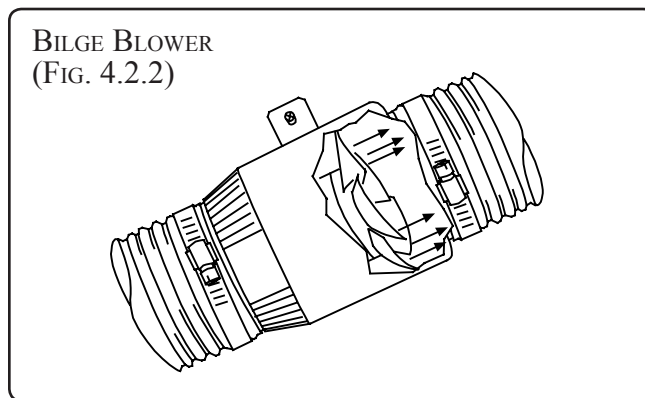

The bilge blower is protected by a fuse on the accessory fuse block located at the helm (see Fig. 6.3.1).

! WARNING

EXPLOSION/FIRE HAZARD – Run blower at least four (4) minutes before starting engine or generator. Check bilge and engine compartment for fumes.



SECTION 4 • BILGE & UNDERWATER GEAR

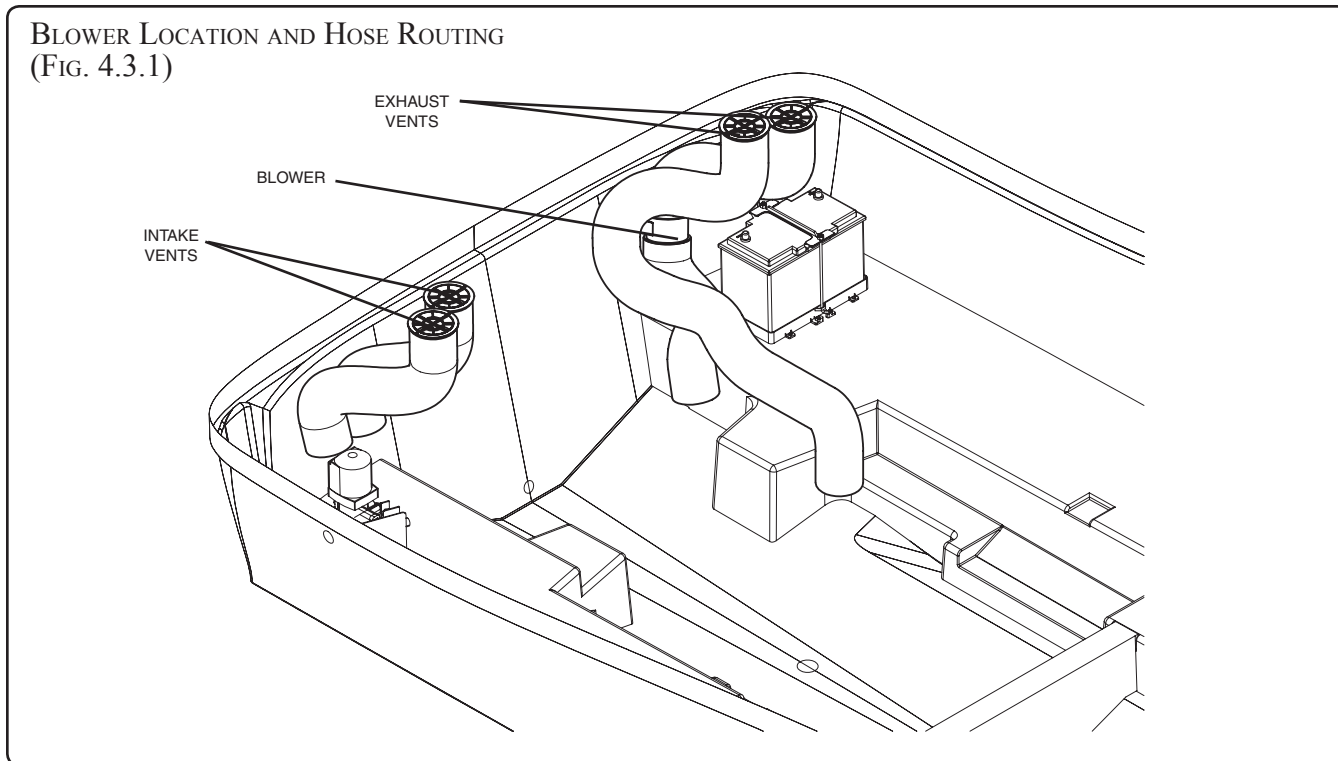

2. ENGINE AND STERN DRIVE

A. MAINTENANCE AND SERVICE

Engine failure away from shore can be dangerous. You must follow the recommended maintenance schedule to best ensure trouble-free operation of your engine and stern drive.

B. VIBRATION AND CAUSES

Some vibration is to be expected in your boat because of the action of the engines and the propeller. But excessive vibration indicates conditions which must be promptly corrected to avoid damage. The following are some conditions which may cause vibrations:

- Weeds, ropes, fishing lines, nets or your own trailing lines can become wrapped around the propeller and/or shaft, causing vibration and loss of speed. Always stop the boat, make sure it is clear to the rear, and then reverse the propeller after going through a weedy area to unwrap and clear away any weeds which may have accumulated. If this doesn't clear the entanglement, and you can't anchor or moor

the boat in shallow water to get to the stern drive in the water, the boat will have to be taken out of the water.

- A badly damaged or distorted propeller or shaft is an obvious cause of vibration. Run at slow speed to shore. **REPLACE IMMEDIATELY.**
- If the engine mounts fail and the engine can contact the hull while it is running, vibration will be felt. Run at slow speed to shore. **REPLACE IMMEDIATELY.**

C. IMPACT TO STERN DRIVE

The stern drive can be damaged by impact, either while trailering or boating. To minimize the possibility of impact damage while trailering, keep the stern drive raised to the trailering position.

The hydraulic system used to raise and lower the stern drive can cushion impact and lessen damage from head-on impacts to the stern drive from underwater objects **BUT ONLY** when the boat is moving forward. There is no protection if the stern drive is struck during reverse operation or from an angle when moving forward.



SECTION 4 • BILGE & UNDERWATER GEAR

If you strike a submerged object, STOP THE ENGINE as soon as possible and examine the stern drive unit for damage. Even if no damage is visible, there could be internal problems or difficulty maneuvering. If you must use the boat after impact, run at the lowest speed possible.

D. PROPELLER SELECTION

IMPORTANT: Installed propeller must allow engine to operate at its specified maximum WOT (wide open throttle) RPM. Use an accurate service tachometer to verify engine operating RPM.

It is the responsibility of the boat manufacturer and/or the selling dealer to equip the power package with the correct propeller. Refer to Quicksilver publication - *Everything You Need To Know About Propellers P/N 90-8614492*. Specified engine WOT and operating RPM range are listed in the *Mercury MerCruiser Operation, Maintenance and Warranty Manual* attached to the engine.

If full throttle operation is below the recommended range, the propeller must be changed to prevent loss of performance and possible engine damage. On the other hand, operating an engine above the recommended operating RPM range will cause higher than normal wear and/or damage.

After initial propeller selection, the following common problems may require that the propeller be changed to a lower pitch:

- Warmer weather and greater humidity cause an RPM loss.
- Operating in a higher elevation causes an RPM loss.
- Operating with increased load (additional passengers, pulling skiers, etc.).

For better acceleration, such as is needed for water skiing, use the next lower pitch propeller. However, do NOT operate at full throttle when using the lower pitch propeller but not pulling skiers.

Because of the many variables of boat design, only testing will determine the best propeller for a particular application. Available propellers are listed in the *Mercury Precision Parts / Quicksilver Accessories Guide*.

! WARNING

If engine is started during propeller maintenance, serious personal injury can occur.

Shut off engine, remove key, shift into neutral, and put tape over ignition switch key slot.

E. PROPELLER REMOVAL AND INSTALLATION

! WARNING

Place a block of wood between the anti-ventilation plate and propeller to protect hands from propeller blades and to prevent propeller from turning when tightening propeller nut.

PROPELLER
(FIG. 4.4.1)

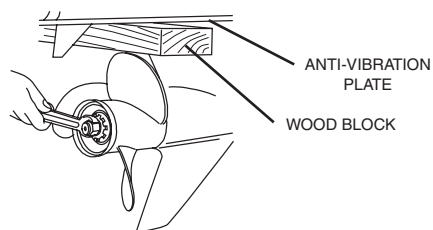

1. Shut off engine, remove key, shift into neutral and put tape over ignition switch key slot.
2. Straighten the bent securing tabs on the propeller nut retainer (Figure 4.4.2).

PROPELLER
(FIG. 4.4.2)

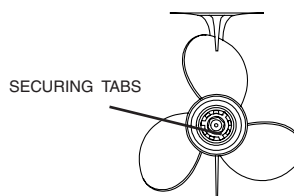

3. Remove the propeller nut retainer, the thrust hub and the continuity washer (Figure 4.5.1) and put them in a secure place. Pull the propeller straight off the shaft. Remove the thrust washer that is behind the propeller. If the propeller is seized to the shaft and cannot be removed by hand,



SECTION 4 • BILGE & UNDERWATER GEAR

special tools are needed. Have the propeller removed by an authorized dealer or trained mechanic.

4. Coat the propeller shaft with an anti-seize lubricant.
5. Install the thrust washer, propeller, continuity washer, thrust hub, propeller nut retainer and the propeller nut onto the shaft (Figure 4.5.1).

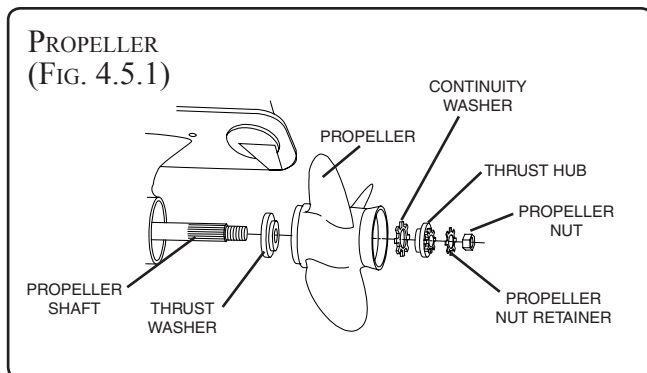

6. Secure the propeller nut by bending three (3) of the tabs of the propeller nut retainer into the thrust hub grooves.

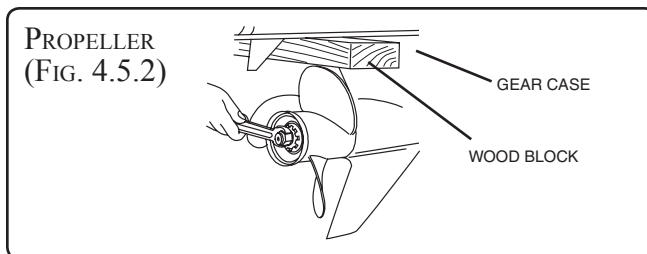

3. UNDERWATER GEAR

A. PROPELLER GENERAL INFORMATION

Propellers should be free of nicks, excessive pitting and any distortions that alter them from their original design. Badly damaged propellers should be replaced, but those that are chipped, bent or merely knocked out of shape can be reconditioned by your marine dealer.

When doing extensive cruising, it is advisable to carry an extra propeller aboard.

BASIC PROPELLER CHARACTERISTICS

Propellers have two basic characteristics:

- Diameter
- Pitch.

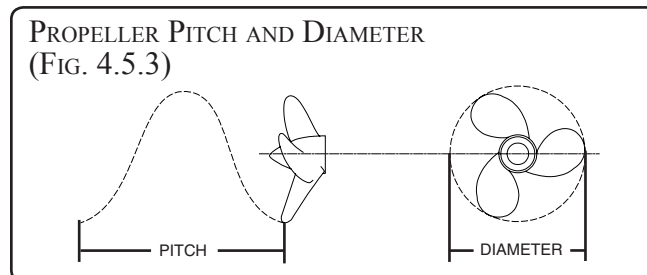

Diameter is that distance measured across the propeller hub line from the outer edge of the 360° that is made by the propeller's blade during a single rotation. Pitch is that distance in inches that a propeller will travel if rotated one revolution without any slippage.

For example, a propeller with a 12-inch pitch, when rotated 360° would, theoretically, advance 12 inches through the water. Actually, no propeller applied to any boat is 100% efficient. No 12-inch pitch blade will, in a single rotation, advance a boat 12 inches. This variance is referred to as slippage.

VENTILATION, ITS CAUSES AND CORRECTIONS

While often called "cavitation," ventilation is really a different effect. At times when a boat enters or leaves a sharp turn, the propeller seems to slip and lose thrust and the engine may over-speed. This problem is normally caused by air or aerated water entering the propeller. (A damaged propeller can also cause ventilation.) Ventilation can usually be corrected by one or both of the following:

1. Replace the damaged or incorrect propeller with the recommended one.
2. With stern drives, set the outdrive at a lesser trim angle (trim the unit downward).



SECTION 4 • BILGE & UNDERWATER GEAR

CAVITATION, ITS CAUSES AND CORRECTIONS

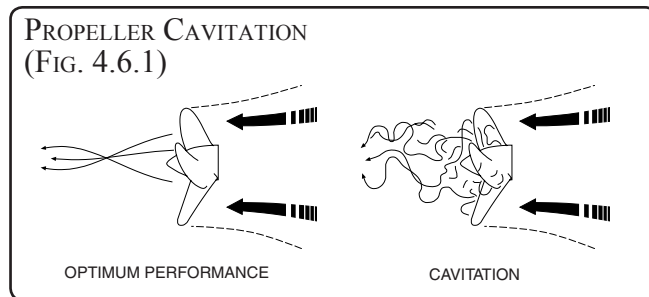

Cavitation is a phenomenon that occurs in all propeller-driven craft under certain conditions. The surface of propeller blades are not perfectly flat, and as water is drawn through the blades to be discharged aft into the propeller's slip stream, the water flowing over the curved surface of the blade encounters areas of greater and less pressure.

In those areas of reduced pressure, air bubbles are formed. When they move out of the low pressure area these bubbles collapse. If they collapse while in contact with an object, such as part of the propeller blade or trim plane, the bubbles create such highly localized forces that they erode the surface of the object. In the case of the propeller, such damage is sometimes called a "burn". It may be caused by an irregularity in the propeller's leading edge, and it should be corrected by reconditioning the propeller or by replacement.

Cavitation is a normal occurrence in modern sport boats, and propeller inspection should be part of routine maintenance.

SECTION 4 • BILGE & UNDERWATER GEAR

4. BILGE LAYOUT

BILGE LAYOUT
(FIG. 4.7.1)

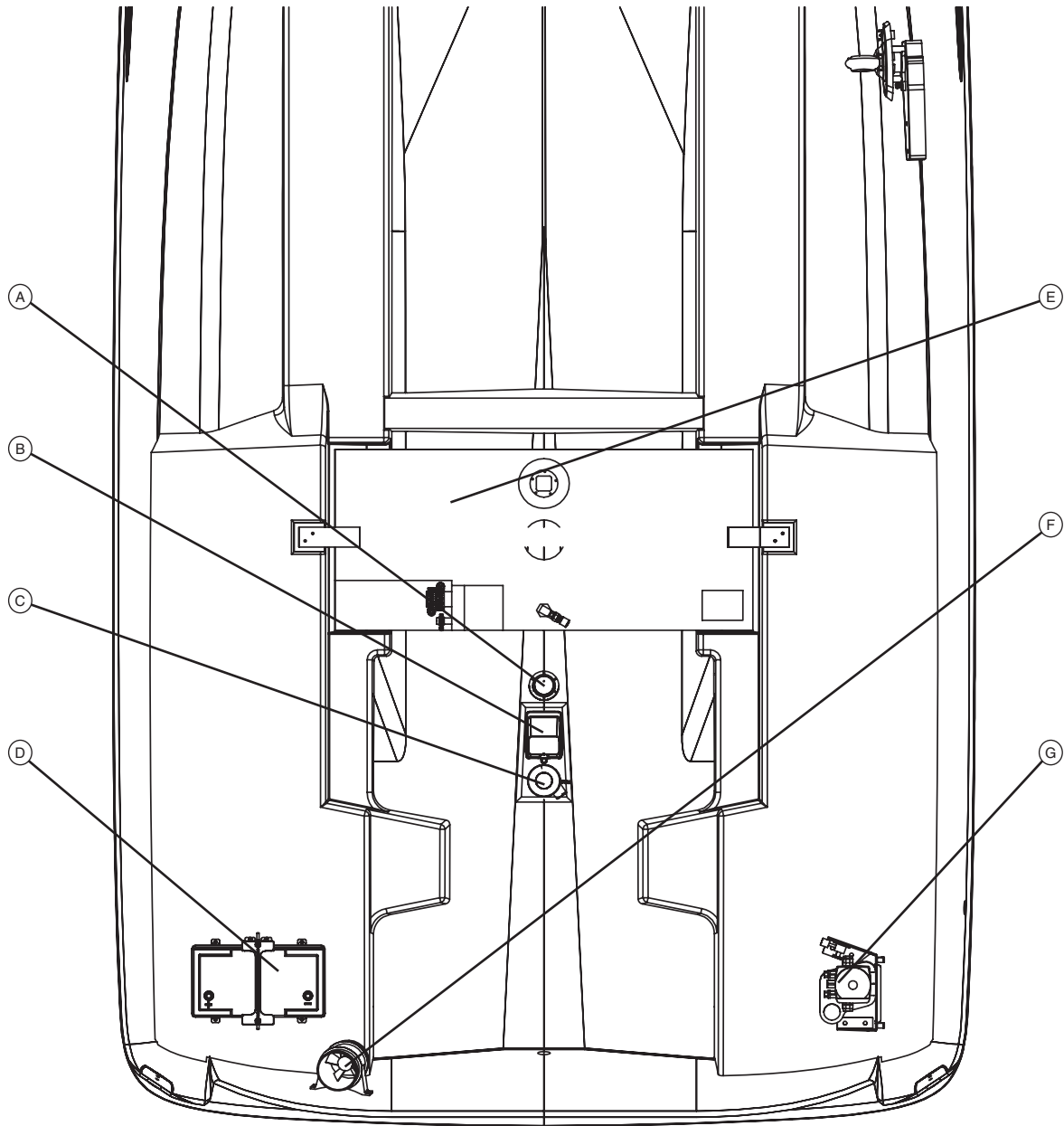

- | | |
|----------------------|---------------------|
| (A) TRANSDUCER (OPT) | (E) FUEL TANK |
| (B) FLOAT SWITCH | (F) BLOWER |
| (C) BILGE PUMP | (G) POWER TRIM PUMP |
| (D) BATTERY | |



SECTION 4 • BILGE & UNDERWATER GEAR

THIS PAGE LEFT INTENTIONALLY BLANK



SECTION 5 • FUEL SYSTEM

1. FUEL SYSTEM

Section 3 - Using Your Boat contains important fueling information. Take time to read all the fuel related information in the Owner's Manual.

The 185 Sport standard gasoline fuel system consists of a 26 gallon (98.4 liter) fuel tank, fuel tank vent, anti-siphon valve, engine fuel supply line and fuel fill (Fig. 5.1.1).

The fuel tank vent serves as a pressure/vacuum release and safety overflow. The fuel vent is located inside the fuel cap on the port aft deck. Periodically check the vent to ensure that it is not clogged.

The fuel pickup at the fuel tank has an anti-siphon valve to prevent fuel from siphoning out in the event of fuel line failure.

A. ANTI-SIPHON VALVE

CARBURETED ENGINES

On all carbureted engines the fuel pickup at the fuel tank has an anti-siphon valve to prevent fuel from siphoning out in the event of line failure (Fig. 5.1.2). In an emergency situation, remove the anti-siphon valve if the engine is not getting fuel. **NOTE:** Replace with new anti-siphon valve or fuel shut off valve as soon as possible as anti-siphon protection is required by federal law.

ANTI-SIPHON VALVE
(FIG. 5.1.2)

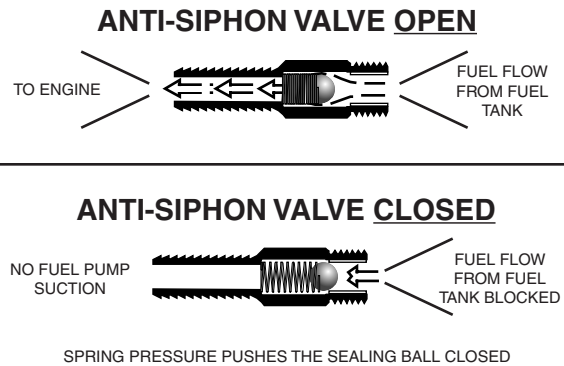

STANDARD FUEL SYSTEM
(FIG. 5.1.1)

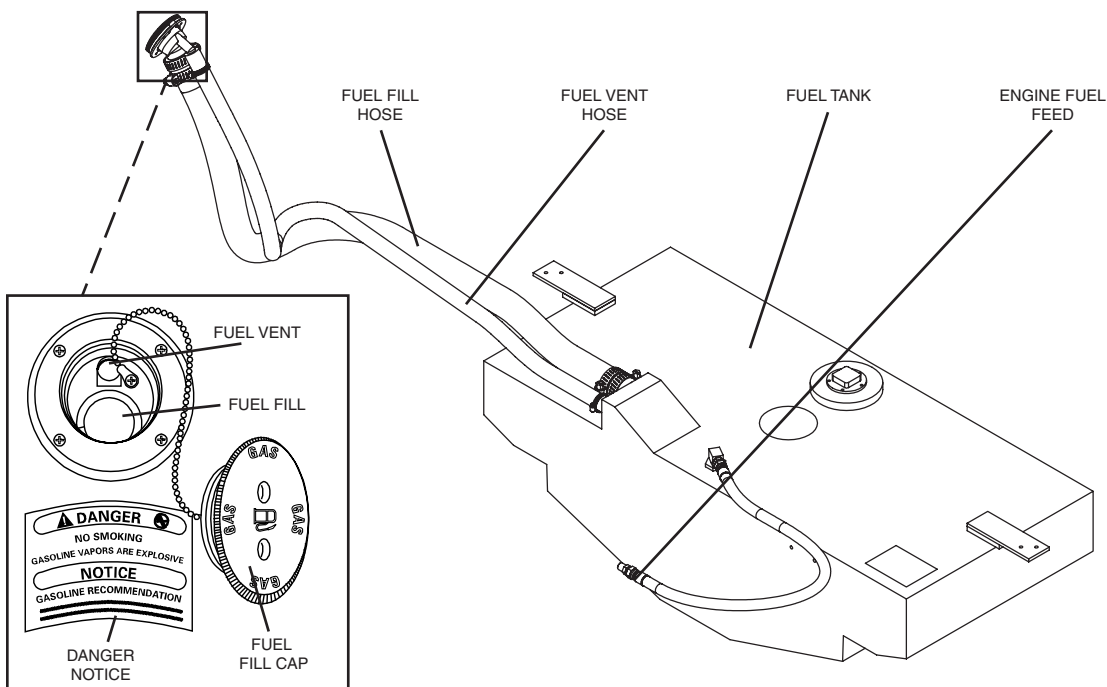

SECTION 5 • FUEL SYSTEM

2. FUELING PRECAUTIONS

Certain precautions must be carefully and completely observed every time a boat is fueled.

A. STATIC ELECTRICITY AND THE FUEL SYSTEM

There is a danger that static electricity can ignite gasoline vapors that have not been ventilated outside an enclosed area. Use extreme caution when fueling your boat from a source outside the regular venues.

Your boat has safety features that can be circumvented by not adhering to standard fueling practices.

Your boat's bonding system is designed to disipate the build-up of static electricity.

Your boat must be in contact with the water or a land based grounding system. Here are some helpful suggestions to keep you safe from static electricity while refueling your boat.

- NEVER fuel your boat in unsafe conditions such as: suspended on a sling or in a situation that increases the likelihood of static discharge.
- NEVER use homemade containers to fill your fuel tank.
- Fuel carried onboard outside of a fixed fuel system should be stored in an approved container or in a portable tank such as provided for outboard engines and be stowed safely outside of the engine or living compartments.
- Shutdown the engine, motors and fans prior to taking on fuel. Any ignition sources should be extinguished before filling the fuel tank.
- Close all ports, windows, doors, and hatches.
- Fueling should never be done at night except in well-lighted areas.
- Always keep the fuel nozzle in contact with the fuel fill plate or the edge of the fuel tank opening

throughout the filling process.

- Allow areas where gasoline vapors could collect to be ventilated before starting the engine(s).
- Wipe any spillage completely and dispose of rags or waste on shore.
- Secure the fill cap tightly.
- Fuel tank should never be filled to capacity. Allow for fuel expansion.
- Portable tanks should only be filled while on the ground; never onboard the boat.

B. GENERAL:

- Check fill plate label to ensure fuel is placed only in fuel tank. Fuel fill plate is located on the port aft deck (Fig. 5.2.1).
- Avoid spills.

FUEL FILL LOCATION
(FIG. 5.2.1)

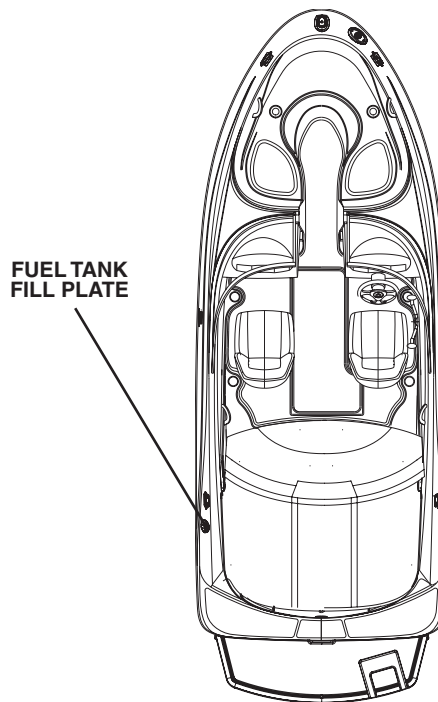

SECTION 5 • FUEL SYSTEM

- Know your fuel capacity and consumption. Record the amount of fuel used since your last fill up, and compute the engine's hourly fuel usage. As a fuel gauge backup check, deduct the average hourly fuel usage from fuel tank capacity.
- Observe the "Rule of Thirds": one-third fuel for trip out, one-third for return and one-third for reserve.
- Allow an additional 15 percent fuel reserve when operating in rough seas.

C. BEFORE AND DURING FUELING CHECKLIST:

- Fire extinguisher – close at hand.
- Mooring – boat tied securely to fueling pier.
- Crew – at least one knowledgeable person present.
- Passengers – unnecessary people off the boat.
- Engine – stopped.
- Electrical equipment, including blower – power off.
- Windows, doors, hatches – closed.
- Smoking material – extinguished.
- Inboard tanks – grounded.
- Filler pipe – marked GAS or DIESEL.
- Fuel nozzle – in contact with filler pipe to prevent static sparks.
- Fill level – fill less than rated capacity of tank; allow for fuel expansion.
- Trim – fuel weight distributed equally.

D. AFTER FUELING CHECKLIST:

- Windows, doors, hatches – open.
- Sniff test – if fuel fumes remain, operate blowers until fumes are gone.
- Fuel tank – secure filler cap.
- Spills – wipe; dispose of rags ashore.



CAUTION

Never start an engine until you are certain that fuel fumes are not present in the engine compartment or elsewhere in the boat.



SECTION 5 • FUEL SYSTEM

THIS PAGE LEFT INTENTIONALLY BLANK



SECTION 6 • ELECTRICAL SYSTEM

1. DC ELECTRICAL SYSTEM

The 12 volt direct current (DC) electrical system (similar to that in your car or truck) derives its power from the battery. The battery is kept charged by the engine-driven alternator.

Ask your dealer for a careful analysis of DC power needs on your boat. It may be necessary to add batteries or auxiliary charging methods to supply adequate power for any additional accessories you wish to add.

BATTERIES

The battery installed in your boat has been selected for its ability to furnish starting power based on engine starting requirements, as well as its ability to power the DC accessories attached to the electrical system. See the table below for the recommended battery for your boat.

! DANGER

DO NOT USE JUMPER CABLES IN THE ENGINE COMPARTMENT.

They can cause an explosion from sparks.

! DANGER

A battery will explode if a flame or spark ignites the free hydrogen given off during charging.

Never use an open flame or strike sparks in the battery area.

To remove the battery cables:

1. Turn off all items drawing power from the battery.
2. Turn the battery switch to the OFF position (Battery switch is optional equipment on some models).
3. Remove the negative cable first, then the positive cable. To replace the cables, first replace the positive cable, then the negative.

! CAUTION

To prevent arcing or damage to the alternator, always disconnect battery cables before doing any work on the engine's electrical system.

BATTERY MAINTENANCE

- Check the fluid levels in the cells approximately every 4 weeks, and weekly in summer and hot zones.
- The fluid level must be between the lower and upper markings.
- Replenish only with distilled water. Do not use metal funnel.
- Coat battery terminal clamps with silicone grease. Keep battery clean and dry.

Battery life is shortened if it is drained to zero charge before recharging. It is recommended that a battery not be discharged more than 50 percent. If the battery does become run down, recharge it as soon as possible.

Running the engine to recharge the battery may not be effective. The alternator only creates charging power at higher engine speeds, so simply idling or trolling will not generate enough power to recharge the battery.

If you need to charge a battery, use only a battery charger designed to charge automotive/marine batteries. Use charger only when battery is disconnected from the boat's electrical circuit. Follow the charger instructions.

If your boat will not be used for several weeks or more remove the battery from the boat and connect it to a charger.

A. RECOMMENDED BATTERIES

The following table describes the recommended marine cranking batteries to install in your boat. All batteries should be of the same type, age & rating.

Application	Group	Volts	CCA*	Reserve	Qty.
Engines	31	12	800	200	1

*COLD CRANKING AMPS

RECOMMENDED BATTERY:

DOUGLAS BATTERY TYPE: 31DCM, ITEM NUMBER: 989 OR EQUIVALENT
DIMENSIONS: 13" x 6^{13/16}" x 10^{1/16}"



SECTION 6 • ELECTRICAL SYSTEM

BATTERY CABLE ROUTING
(FIG. 6.2.1)

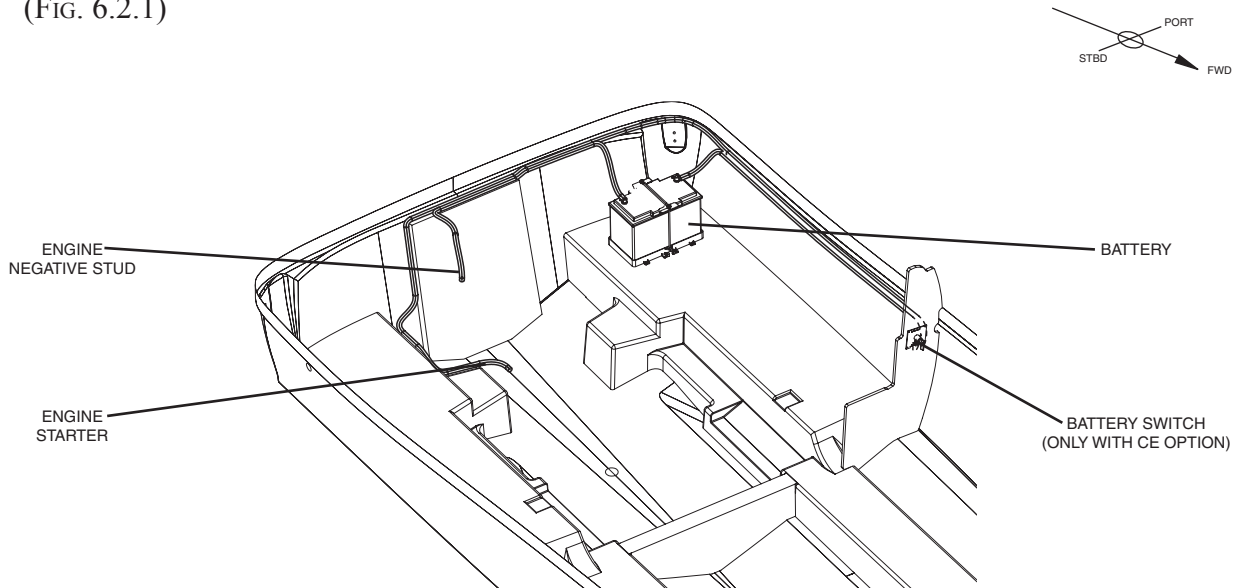

2. IGNITION PROTECTION

All electrical components in the engine compartment must be ignition-protected to avoid the possibility of creating sparks in a gasoline environment.

⚠ DANGER

GASOLINE VAPORS CAN EXPLODE

Use **ONLY** Marine-rated parts to replace such items as starters, distributors, alternators, generators, etc.

Do not use automotive parts for these components or any jumper cables because they are not ignition-protected and could cause a fire or explosion.

Protective terminal covers, such as rubber boots on electrical connections, must be in place when engine is operating or when working in the engine compartment.

Jumper cables are not ignition-protected. **DO NOT USE** jumper cables in the engine compartment. The engine compartment may accumulate dangerous explosive gasoline fumes/vapors and hydrogen gas from batteries being charged. A spark produced when connecting a jumper cable can cause an explosion.

3. FUSES

The accessory fuse block is located at the helm in the compartment below the steering wheel (Fig. 6.3.1). There are also fuses for the Bilge Pump and Stereo Memory located in the engine compartment on the port transom (Fig. 6.2.2). If you need to replace a fuse, **use only the same amperage as the original**. It is recommended that you carry spare fuses. See Fig. 6.2.2 and 6.3.1 for the proper fuse sizes.

BILGE BLOWER
(FIG. 6.2.2)

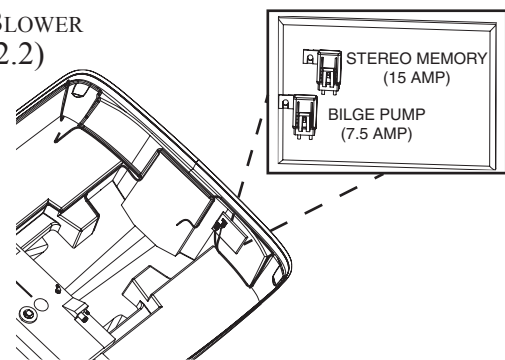

SECTION 6 • ELECTRICAL SYSTEM

ACCESSORY FUSE BLOCK
(FIG. 6.3.1)

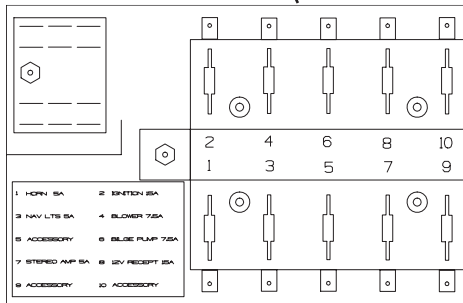
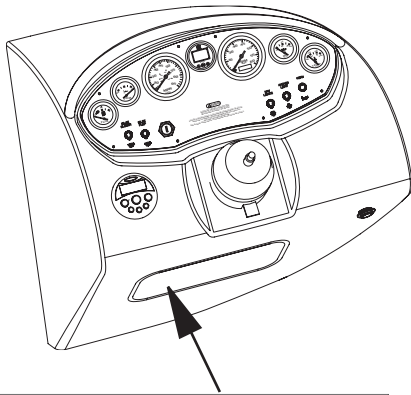

FUSE NAME	FUSE AMPERAGE 12VDC
-----------	---------------------

1. HORN	5
2. IGNITION	15
3. NAV LIGHTS	5
4. BILGE BLOWER	7.5
5. ACCY	BLANK
6. BILGE PUMP	7.5
7. STEREO AMP	5
8. RECEPTACLE	15
9. ACCY	BLANK
10. ACCY	BLANK

FUSE CONDITION (ATO TYPE FUSE)

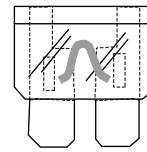

GOOD FUSE

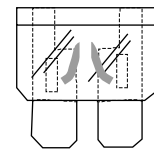

BLOWN FUSE

! WARNING

Use of higher amperage fuses or breakers is a fire hazard.

Use fuses and breakers having the same amperage rating as the original or as specified.

If a fuse is replaced with one of lower amperage, it will not be sufficient to carry the electrical load of the equipment it is connected to and will cause nuisance fuse failure.

If a fuse is replaced with one of higher amperage, it will not provide adequate protection against an electrical malfunction and will create a fire hazard.

4. 12 VOLT ACCESSORY RECEPTACLE

Your boat has a 12 volt accessory receptacle at the helm. The receptacle is a cigarette lighter style plug that may be used with any 12 volt accessories using this type of plug.

12 VOLT ACCESSORY RECEPTACLE
(FIG. 6.3.2)

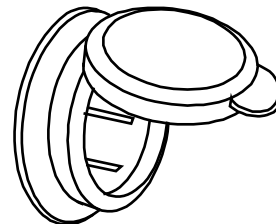

SECTION 6 • ELECTRICAL SYSTEM

5. LIGHTING

Your boat is equipped with a variety of different lighting fixtures (See Fig. 6.7.1 and 6.8.1). **Always replace a bulb using the type and wattage of the original bulb.**

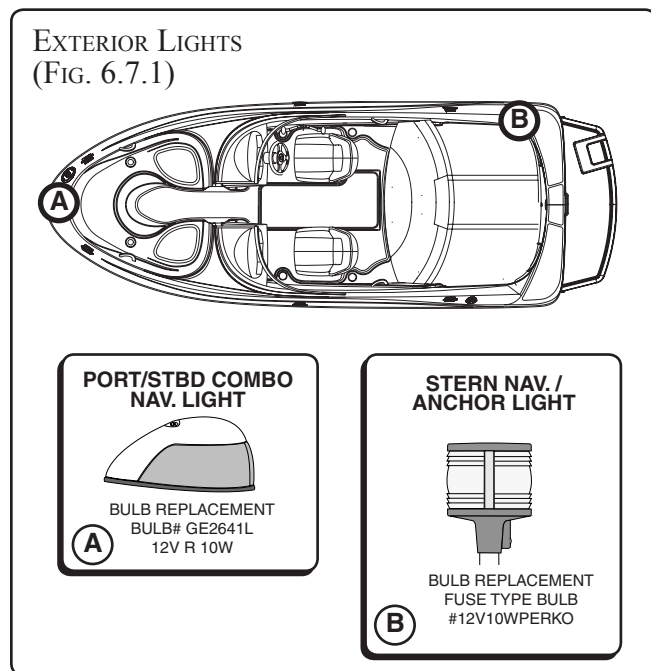

6. ELECTROLYTIC CORROSION AND ZINC ANODES

Electrolytic corrosion of metals on power boats can result in rapid and serious deterioration of metal parts. You must set a regular schedule and look for the possibility of electrolytic corrosion (the deterioration of metals due to dissimilar characteristics when placed in salt water). It is your responsibility to check for and replace parts damaged due to electrolytic corrosion.

To minimize electrolytic corrosion of the metals on your boat, zinc anode plates are provided on your boat to protect underwater hardware. Zinc, being much less "noble" than the copper-based alloys and aluminum used in underwater fittings, will deteriorate first and protect the other metals.

Stern drives are fitted with zinc anodes on their lower units (refer to your Engine Owner's Manual for their locations). If your boat is equipped with trim tabs, zinc plates are installed on each of the trim tabs.

Zinc anodes require replacement about every six months, if the boat is operated in salt water. In fresh water, the zinc anodes can be replaced about once a year.

If the anodes deteriorate more rapidly than this, there is probably a stray current problem within the boat or at the slip or mooring.

If the anodes do not deteriorate, they are not protecting the other metallic parts of your boat. This can be caused by loose anodes or by low grade zinc or by not having a solid electrical contact between the anode and the metal it contacts, or by paint on the anodes.

If the anodes are deteriorating rapidly, or not at all, contact your dealer.

When an AC shore power system is connected to the boat, the underwater metal fittings will, in effect, be connected through the water to grounded metals ashore. This results in the zincs being consumed at a faster rate unless the marina maintains a protective system to prevent this. When the marina provides a zinc anode in the water bonded to the metal outlet box on the dock, zinc loss on the boat will be reduced. Do not connect this zinc to the boat's ground system.

It is extremely important that all electrically-operated DC equipment and accessories be wired so that the ground polarity of each device is the same as that of the battery. Your boat has a negative ground system. The zinc anode is connected to every metal item in the boat (fuel tanks, underwater gear, etc.) via the green bonding wire.

CAUTION

Never disconnect the green wire (safety ground) from the engine terminal.

NOTICE

DO NOT PAINT BETWEEN THE ZINC AND THE METAL IT CONTACTS, AND DO NOT PAINT OVER THE ZINC.



7. MARINE ELECTRONIC CATHODIC ANTI-CORROSION SYSTEM

The automatically controlled Cathodic Anti-Corrosion System for marine installation protects underwater metals from the effects of corrosion and electrolysis on stern drives. The system components are designed for marine service. DO NOT PAINT THE MERCATHODE® SYSTEM.

The anode and reference electrode are attached to the electrode assembly under each stern drive unit. The solid state controller is mounted within a plastic housing on the transom in the bilge.

Maintenance

The Mercathode® system must be tested to ensure adequate output. The test should be performed every 100 hours or annually. Contact your authorized Sea Ray® dealer to arrange for this test. Refer to the engine operator's manual for more detailed information.

8. ELECTRICAL SCHEMATICS

This owner's manual contains electrical schematics and wiring harness illustrations for your boat. These electrical schematics were generated by electrical CAD designers at the engineering division for technical reference and service technicians. Sea Ray® does not recommend that you attempt to work on the boat's electrical system yourself. Instead, we recommend that you take your boat to your authorized Sea Ray® dealer for service. Sea Ray® reserves the right to change or update the electrical system on any model at any time without notice to the consumer and is NOT obligated to make any updates to units built prior to changes.



SECTION 6 • ELECTRICAL SYSTEM

THIS PAGE LEFT INTENTIONALLY BLANK



185 SPORT ELECTRICAL SCHEMATICS

DC WIRING DIAGRAM (1 OF 2)
(FIG. 6.7.1) DRAWING NO. 09-601 (1 OF 2) REVISION 3

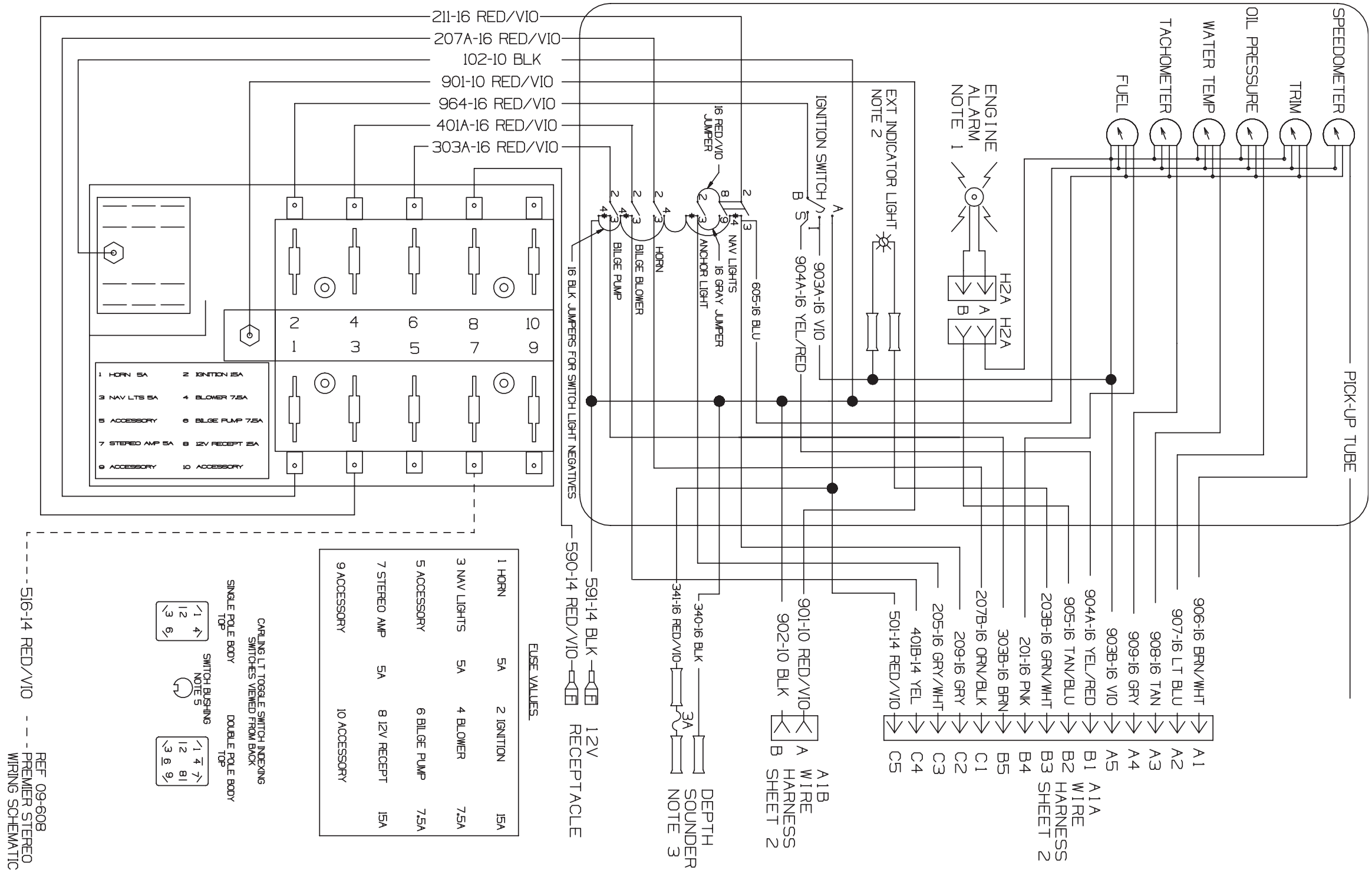

185 SPORT ELECTRICAL SCHEMATICS (CONTINUED)

DC WIRING DIAGRAM (2 OF 2)
 (FIG. 6.8.1) DRAWING NO. 09-601 (2 OF 2) REVISION 1

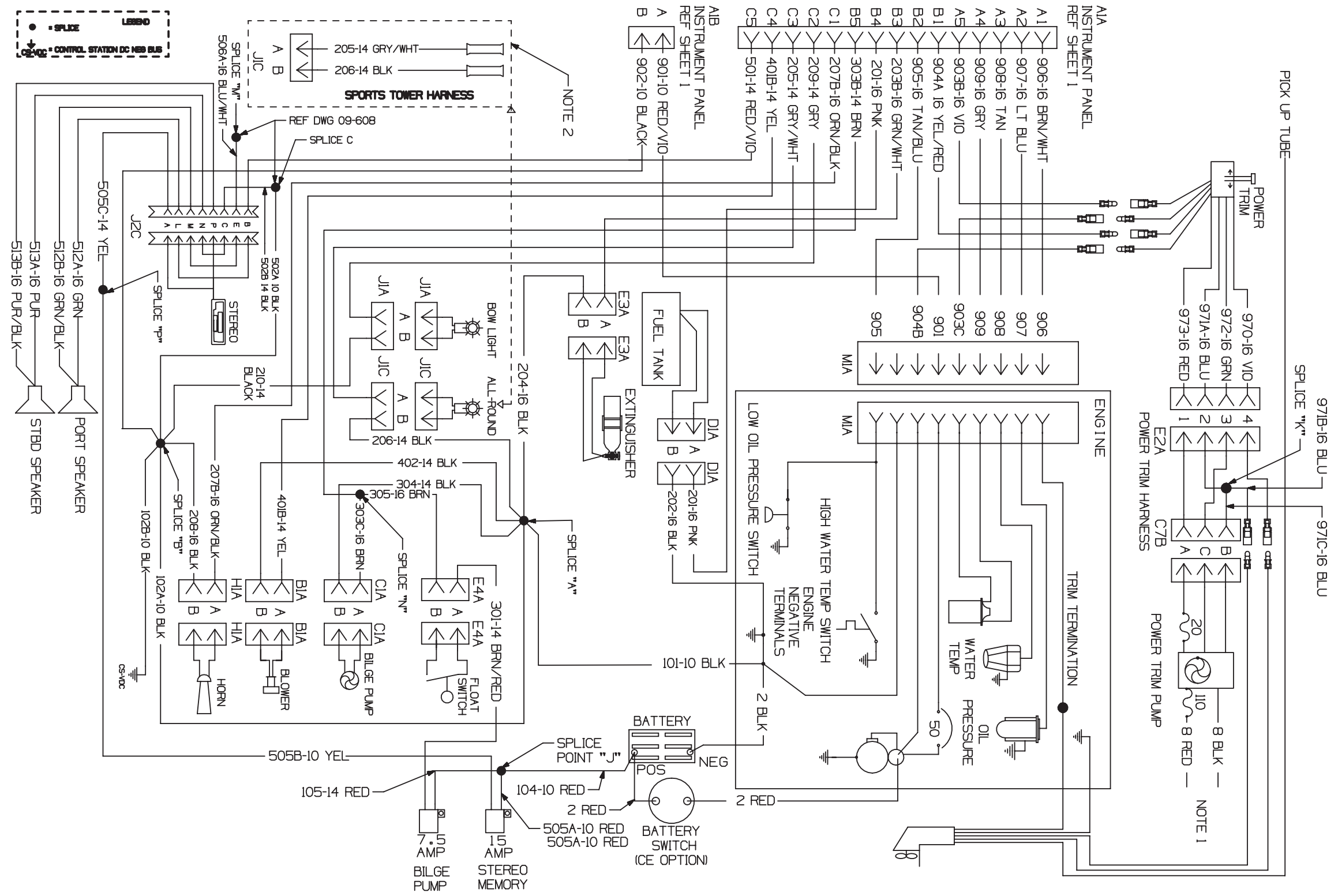

185 SPORT ELECTRICAL SCHEMATICS (CONTINUED)

PREMIER STEREO WIRING SCHEMATIC
(FIG. 6.9.1) DRAWING NO. 09-608

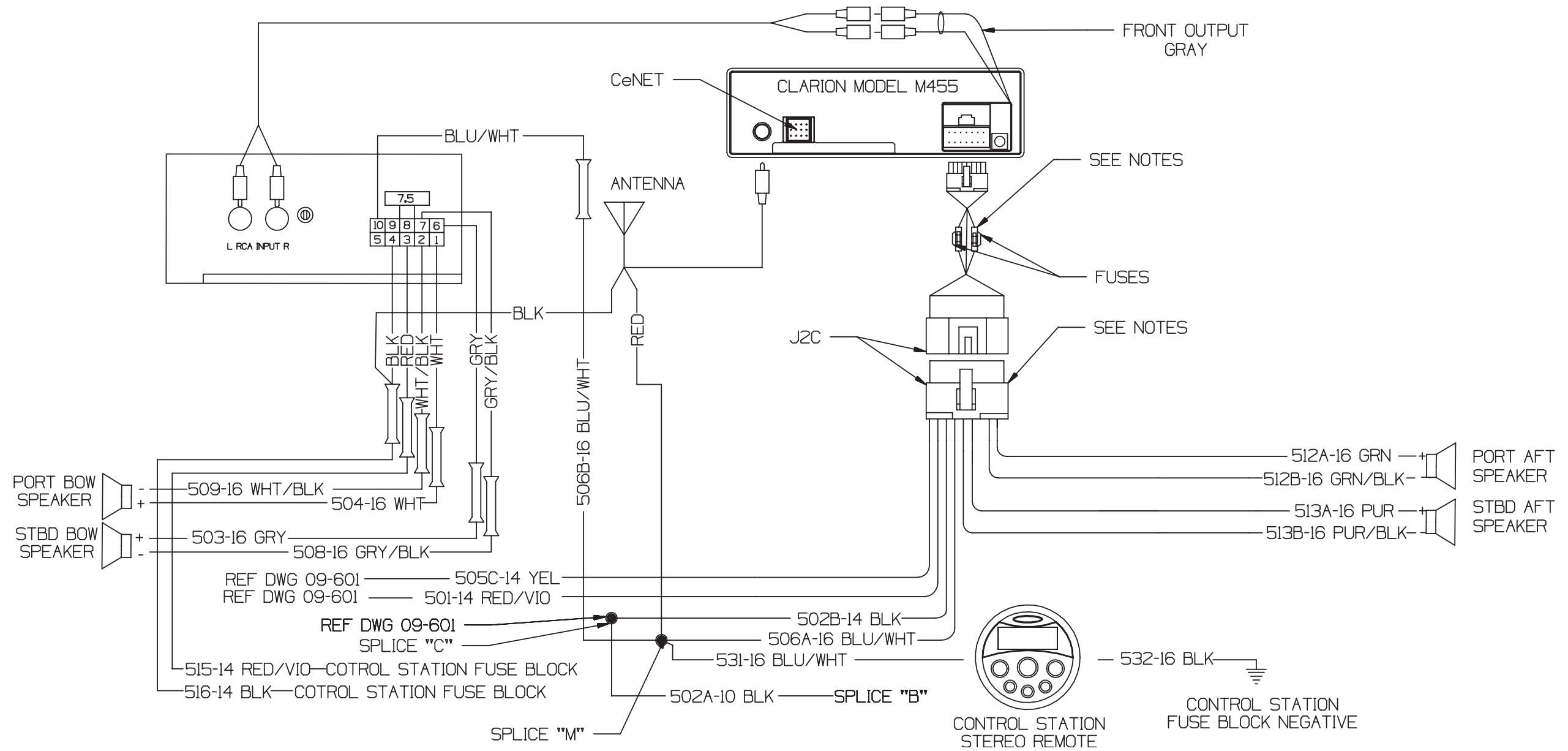

185 SPORT ELECTRICAL SCHEMATICS (CONTINUED)

SATELLITE STEREO DIAGRAM
(FIG. 6.10.1) DRAWING NO. 09-715

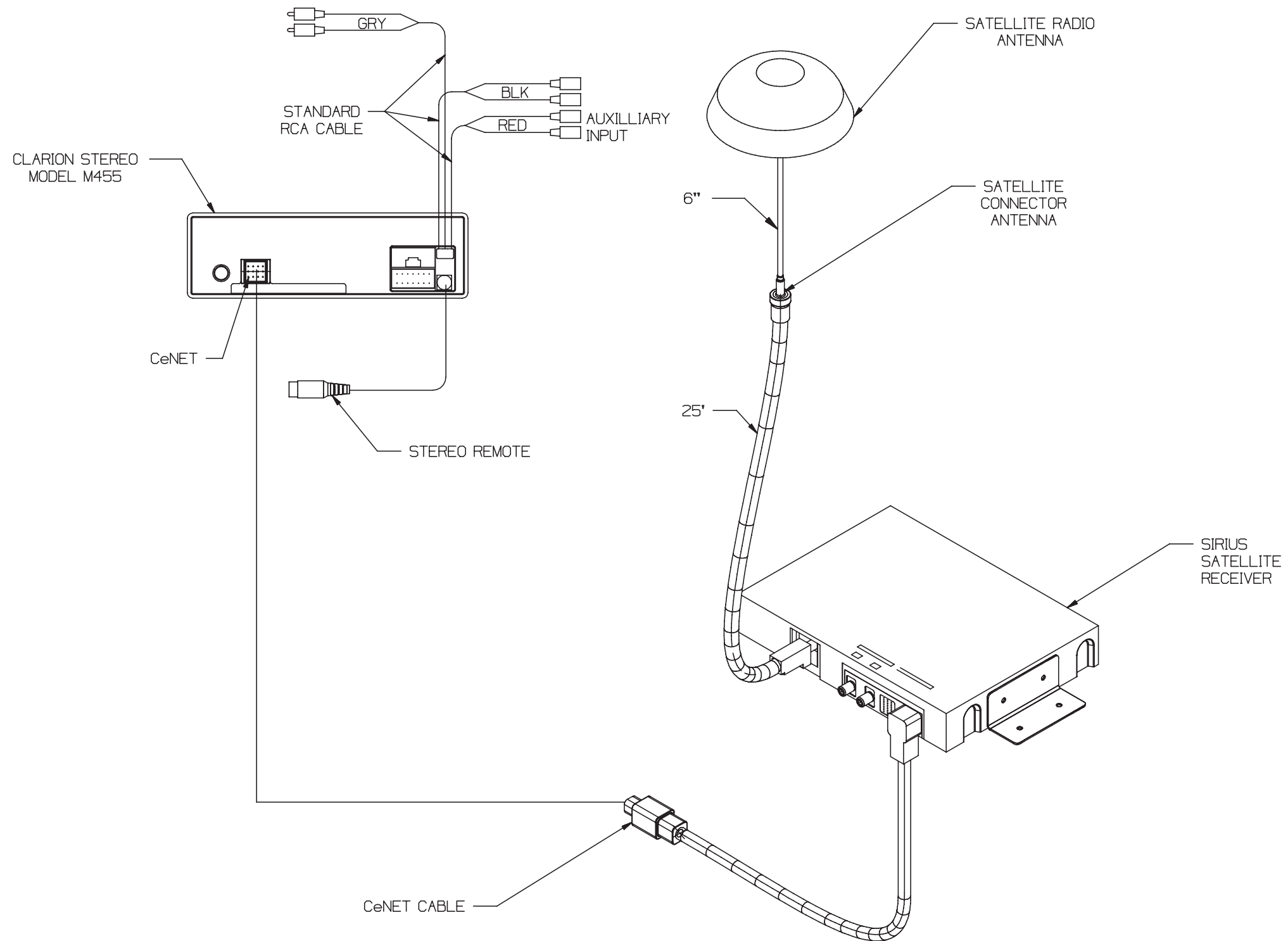

185 SPORT ELECTRICAL SCHEMATICS (CONTINUED)

WIRING HARNESS
(FIG. 6.11.1) DRAWING NO. 09-871

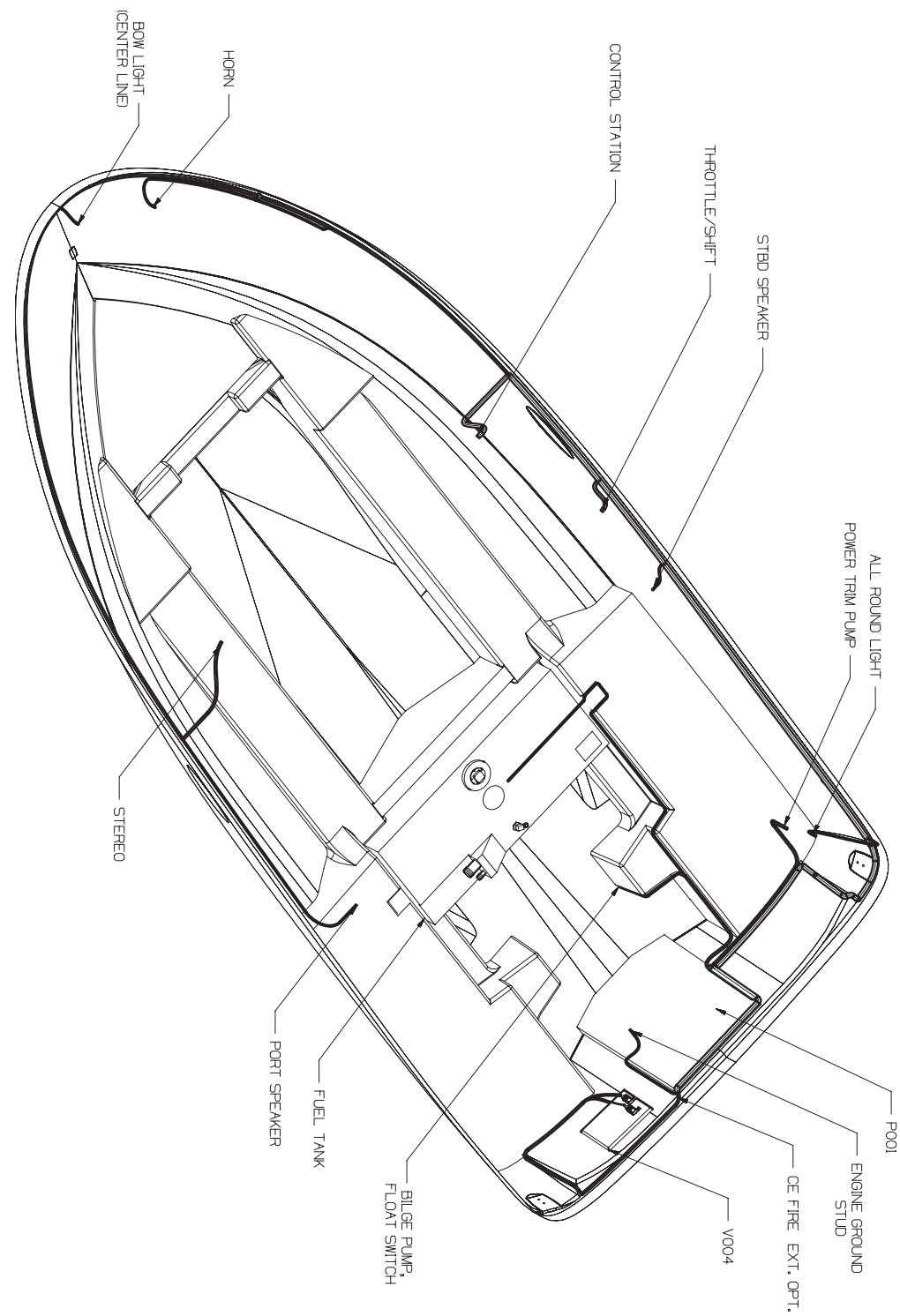

PREMIER STEREO HARNESS
(FIG. 6.11.2) DRAWING NO. 09-874 (1 OF 2)

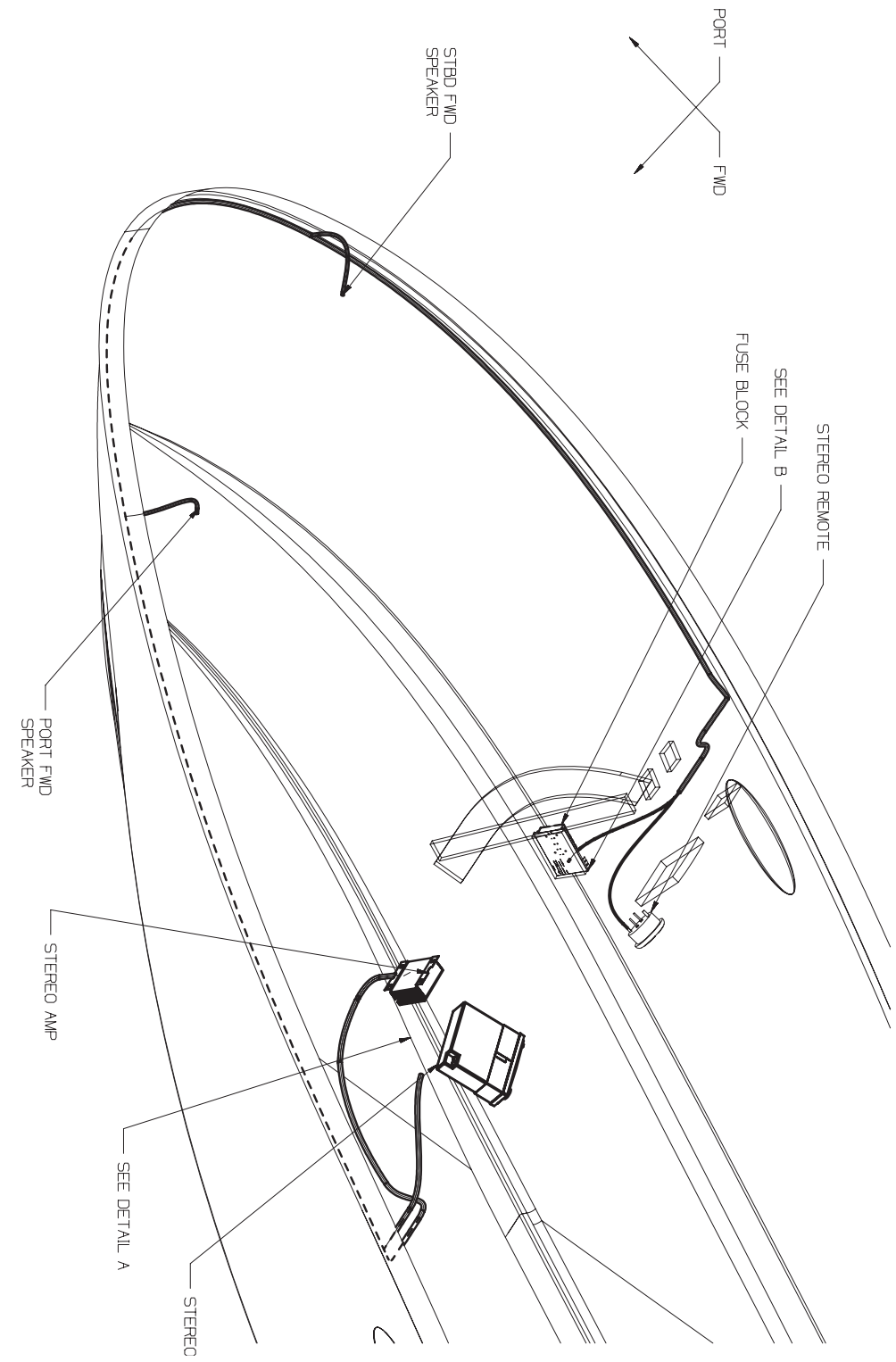

THIS PAGE LEFT INTENTIONALLY BLANK



SECTION 7 • OPTIONS & ACCESSORIES

1. LAYOUT AND ACCESSORY LOCATIONS

Pages 2.4 through 2.5 show the location and arrangement of the most important equipment and components on your boat. Using these drawings, walk through your boat, locate the features shown, and become familiar with their operation and maintenance.

2. ENTERTAINMENT CENTER

The entertainment center equipment options may vary from boat to boat. Refer to the Owner's Manual Packet to find individual instructions for the equipment installed on your boat.

REFER TO OWNER'S MANUAL PACKET FOR INSTRUCTIONS AND WARRANTY INFORMATION.

A. 12 VOLT STEREO

The 12 volt AM/FM radio single CD stereo is located in the port glove box.

The system includes two (2) water proof speakers. The Premier Stereo upgrade includes an amplifier, power antenna, four (4) speakers, a digital remote control located at the control station and is satellite radio ready.

If installed, the premier stereo amplifier is protected by the stereo fuse on the accessory fuse block. The stereo memory is protected by a fuse in the engine compartment (see Fig. 6.2.2).

REFER TO OWNER'S MANUAL PACKET FOR INSTRUCTIONS AND WARRANTY INFORMATION.

3. FIRE EXTINGUISHER PORT

Boats not equipped with the automatic fire extinguisher option are equipped with a fire extinguisher discharge port. In the event of a fire, a fire extinguisher can be inserted through the port and discharged into the engine compartment without having to open the engine box. Do not open the engine compartment immediately! This feeds oxygen to the fire and flashback could occur.

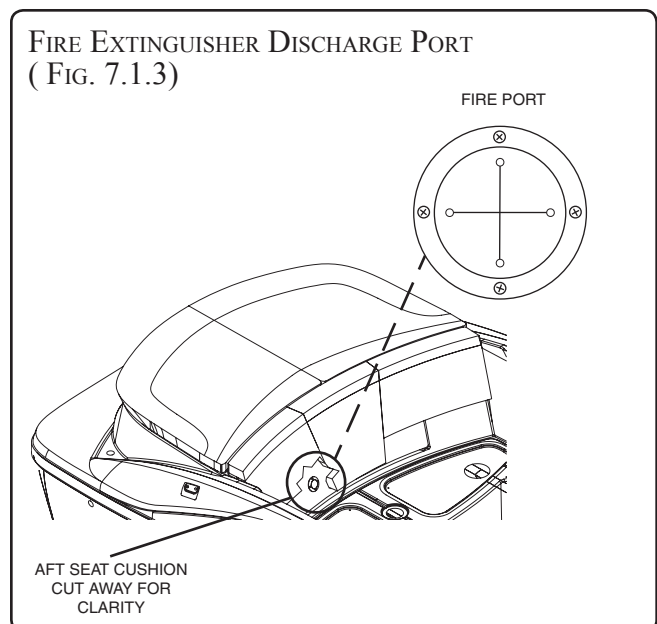
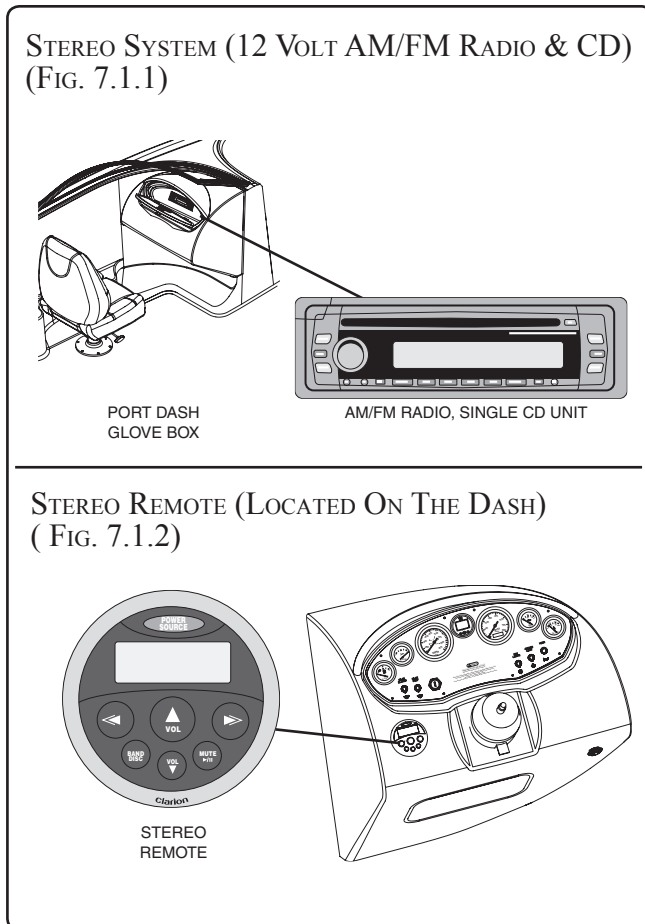

SECTION 7 • OPTIONS & ACCESSORIES

IF A FIRE OCCURS, IMMEDIATELY SHUT DOWN ALL ENGINES, POWERED VENTILATION, ELECTRICAL SYSTEMS AND EXTINGUISH ALL SMOKING MATERIALS. DO NOT IMMEDIATELY OPEN THE ENGINE COMPARTMENT!! THIS FEEDS OXYGEN TO THE FIRE AND FLASHBACK COULD OCCUR.

WARNING

- In case of fire **DO NOT** open engine box or compartment.
- Shut down engine and blowers.
- Continuously discharge entire contents of portable fire extinguisher through port immediately.

4. AUTOMATIC FIRE EXTINGUISHER SYSTEM (OPTIONAL)

AUTOMATIC FIRE EXTINGUISHER (FIG. 7.2.1)



Your boat may be equipped with an automatic fire extinguisher system located in the engine compartment. In the event of a fire, the heat sensitive automatic head will release the extinguishant as a vapor, totally flooding the area in fire-killing concentrations.

WHEN ACTUATION OCCURS, IMMEDIATELY SHUT DOWN ALL ENGINES, POWERED VENTILATION, ELECTRICAL SYSTEMS AND EXTINGUISH ALL SMOKING MATERIALS. DO NOT IMMEDIATELY OPEN THE ENGINE COMPARTMENT!! THIS FEEDS OXYGEN TO THE FIRE AND FLASHBACK COULD OCCUR.

Allow the extinguishant to “soak” the compartment for at least fifteen (15) minutes and for hot metals or fuels to cool before cautiously inspecting for cause of fire. Have portable extinguishers at hand and ready. Do not breathe fumes or vapors caused by the fire.

A. EXTINGUISHER INDICATOR LIGHT

The system indicator light is wired to the ignition and is turned ON when the ignition is turned ON. The indicator light, located on the dash panel, indicates to the helmsman when the unit has discharged. Under normal circumstances, when the ignition is ON the charge indicator light is ON. If the unit discharges, the light will go OFF.

AUTOMATIC FIRE EXTINGUISHER INDICATOR LIGHT (FIG. 7.2.2)

AUTOMATIC HALON SYSTEM

1. LIGHT ON-UNIT CHARGED
2. LIGHT OFF-UNIT DISCHARGED
3. IF SYSTEM DISCHARGES. SHUT DOWN ENGINE(S), BLOWERS AND ELECTRICAL SYSTEMS



B. MANUAL FIRE EXTINGUISHING SYSTEM PULL HANDLE

Located at the control station, the manual fire extinguisher system allows the operator to manually activate the automatic extinguisher in the engine room. Early detection and use of the

MANUAL FIRE EXTINGUISHING SYSTEM PULL HANDLE (FIG. 7.2.3)

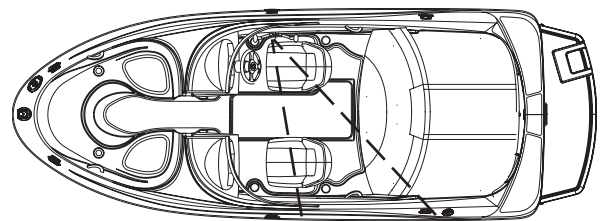

TO MANUALLY ACTIVATE THE ENGINE ROOM FIRE EXTINGUISHER:

1. PULL PIN
2. PULL HANDLE

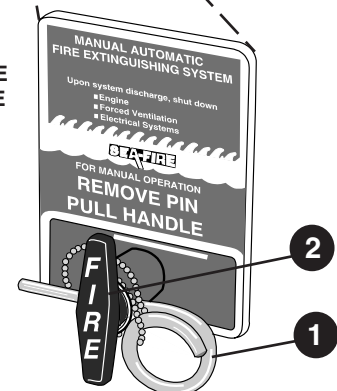

SECTION 7 • OPTIONS & ACCESSORIES

manual override system will reduce fire damage by eliminating the time necessary for heat in the engine room to rise to a temperature necessary to activate the automatic fire extinguisher.

TO OPERATE:

1. Pull pin securing the handle.
2. Pull red FIRE handle quickly and briskly.

C. SAFETY PIN

The safety pin is used on boats equipped with the Manual Fire Extinguishing System Pull Handle. The safety pin, located at the neck of the extinguisher bottle in the engine room is for shipping and transfer of the bottle only. The pin **MUST** be removed in order to manually operate the system.

ENGINE ROOM FIRE EXTINGUISHER
(FIG. 7.3.1)

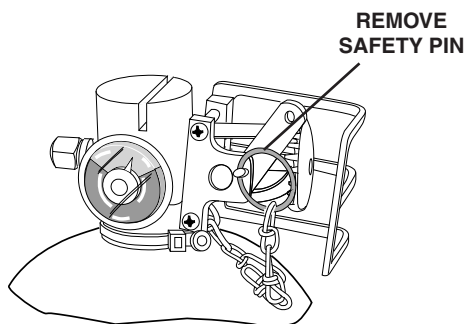

NOTE: THE MANUAL SYSTEM WILL NOT OPERATE
IF SAFETY PIN IS INSTALLED.

8. CANVAS

The Bimini Top should not be used when the vessel speed exceeds 45 MPH. Damage to the boat or Bimini may occur.

Attached to the inside of the Bimini Top is a DANGER tag for Carbon Monoxide Gas (CO) buildup and a WARNING tag for limiting speeds when Bimini Top canvas is installed. The rear (aft) curtain also has a WARNING tag stating "The Aft Curtain must not be used while engine is running or boat is underway". If your canvas does not have these tags, or they become lost or are unable to be read, contact your dealer for replacement labels.

DANGER

If the cockpit is totally enclosed with canvas covers and curtains while the engine is running or boat is moving, carbon monoxide will build up and cause death or permanent injury.

Do not use the rear (aft) curtain while engine is running or boat is moving.

For your safety, decide which canvas pieces you want to remove or install before you leave the boat slip or off-load your boat from the trailer into the water. Removing or installing canvas on the water can be difficult since rough water or wakes can cause you or your passengers to lose their balance while attempting canvas removal or installation.

For safety and ease of installation and removal of canvas, use at least two people. Know which canvas piece(s) that you are to install or remove.

The following canvas pieces are available individually as options:

- Sunbrella® Bimini Top w/ Boot
- Cockpit and Tonneau Covers w/ storage Bag
- Travel/Storage Cover

A. INSTALLATION TIPS

- **Zippers:** Zippers are located on each canvas piece. Make sure canvas is centered over the metal canvas support rods (bows). When attaching any canvas piece, zip the zippers only partially. This helps to hold the piece in place and relieves tension, helping the other sides zip or snap more easily. After all the sides of the piece are snapped in place, finish zipping all the zippers. This will ensure a tight fit.
- **Adjustable Support Rods:** Adjustable support rods are located on the Bimini Top. There is an outside tube and an inside tube. Push in the button to adjust for longer or shorter rod lengths.



SECTION 7 • OPTIONS & ACCESSORIES

B. CANVAS CARE AND MAINTENANCE

See Section 9, for instructions on the care and maintenance of your canvas.

 **DANGER**

In rainy weather and/or cold weather, fresh air must circulate through boat to avoid carbon monoxide poisoning.

See Section 1.4, Carbon Monoxide, for more details.

 **DANGER**

Exhaust fumes from engines contain deadly carbon monoxide gas (CO). Boats enclosed with canvas or with poor ventilation are most likely to collect fumes.

CO sickness symptoms include headache, nausea and dizziness. Do not mistake these symptoms for sea sickness.

Ventilate boat. See Section 1.4, Carbon Monoxide, for more details.

9. HORN

The horn is operated by a momentary switch on the dash and is protected by a fuse on the accessory fuse block located at the helm.

REFER TO OWNER'S MANUAL PACKET FOR INSTRUCTIONS AND WARRANTY INFORMATION.



SECTION 8 • REQUIRED INSPECTION, SERVICE & MAINTENANCE

Routine inspection, service and maintenance of your boat's systems is vital to assure your safety, as well as for prolonging the life of your boat. You should develop regular routines for inspecting your boat. The chart below summarizes inspection, service and maintenance activities. This section also contains descriptions of some convenient methods for evaluating the condition of some of your boat's systems.

The interval between necessary service or maintenance is highly variable, depending on the environment your boat is in, and on the severity of operating conditions. For example, corrosion of parts on boats operated in salt water proceeds much faster than the corrosion of parts on a boat operated in fresh water. The intervals listed below are recommended maximums, and you must reduce the time between inspections if your observations indicate the need.

1. SUMMARY GUIDE FOR INSPECTION, SERVICE AND MAINTENANCE

ITEM	REQUIRED MAINTENANCE/SERVICE	REFERENCE SOURCE	INTERVAL				
			BEFORE EVERY USE	AFTER FIRST 20 HOURS	EVERY 25* OR 50 HOURS	EVERY 50* OR 100 HOURS	EVERY 6 MOS. OR ANNUALLY
Battery	Check water level	Owner's Manual p. 6.1	•	•	•		
Bilge Area	Clean and check	Owner's Manual p. 4.1					•
Bilge Blower	Hose connections tight	Owner's Manual p. 4.2			•		•
Bilge Pump	Float switch operates freely	Owner's Manual p. 4.1					•
Canvas	Clean	Owner's Manual p. 9.2	As Needed				
Controls							
<i>Steering</i>	Check for proper operation		To be done by Sea Ray dealer every six months				
	Power steering oil level	Engine Manual	•				
<i>Gear Shift & Throttle</i>	Lubricate. Include all shift linkage and pivot points	Engine Manual		•		•	•
Electrical							
<i>Connections</i>	Check for looseness		To be done by Sea Ray dealer annually				
Engine							
<i>Alarm</i>	Check	Engine Manual	•				
<i>Cooling System</i>	Check for leaks	Engine Manual	•				
<i>Connections</i>	with engine running						
<i>Crankcase ventilating system</i>	Clean	Engine Manual		•		•	
<i>Drive belts</i>	Check	Engine Manual	•				
<i>Exhaust System</i>	Check for leaks	Engine Manual	•	•		•	
<i>Flame Arrestor</i>	Clean	Engine Manual		•		•	
<i>Fuel Filter</i>	Replace	Engine Manual				•	
<i>Mounts (Fasteners)</i>	Tighten	Engine Manual		•			•
<i>Oil and Filter</i>	Replace	Engine Manual				•	•
<i>Oil Level</i>	Check	Engine Manual	•				
Stern Drive (With Stern Drive Engine Option)							
<i>Fluid level</i>	Check level	Engine Manual	•				
<i>Fluid</i>	Replace	Engine Manual					•

*Use in salt water or other severe operating conditions requires shorter maintenance/service intervals

**May not be on your boat



SECTION 8 • REQUIRED INSPECTION, SERVICE & MAINTENANCE

SUMMARY GUIDE FOR INSPECTION, SERVICE AND MAINTENANCE

ITEM	REQUIRED MAINTENANCE/SERVICE	REFERENCE SOURCE	INTERVAL				
			BEFORE EVERY USE	AFTER FIRST 20 HOURS	EVERY 25* OR 50 HOURS	EVERY 50* OR 100 HOURS	EVERY 6 MOS. OR ANNUALLY
Fuel System							
<i>Connections & Lines</i>	Check for leaks	Engine Manual	•	•	•		
<i>Tank</i>	Check for leaks	Owner's Manual p. 5.1	•	•	•		
<i>Water Separating Fuel Filter</i>	Replace	Engine Manual		•			•
Sliding Seats and Ladder							
<i>Helm Seat</i>	Spray slider with light coating of spray lubricant				•		
<i>Transom Swim Ladder</i>	Spray slider with light coating of spray lubricant				•		
Propeller	Inspect for damage		Always after striking object				
Seaworthiness							
<i>Bilge drain plug</i>	Installed and tight	Owner's Manual p. 4.1	•				
<i>Hull damage Stern drive</i>	Check for loose, damaged or missing parts		Always after striking object				
Topside & Supplies	Check for loose, damaged or missing parts	Owner's Manual p. 8.5					•
<i>Anchor rope</i>	Check rope for wear						•
Transmission							
<i>Oil Strainer Screen</i>	Clean		To be done by Sea Ray dealer annually				
Trim Tabs							
<i>Fluid</i>	Check and add as needed	Trim Tab Manual		•			
Zincs							
<i>Trim Tabs</i>	Check and replace as needed	Trim Tab Manual	Every 25 hours of operation				

***Use in salt water or other severe operating conditions requires shorter maintenance/service intervals**

****May not be on your boat**



SECTION 8 • REQUIRED INSPECTION, SERVICE & MAINTENANCE

2. USEFUL SERVICE INFORMATION

OWNER _____

HOME PORT _____

BOAT NAME _____

REGISTRATION NUMBER _____ STATE _____

HULL SERIAL NUMBER _____

WARRANTY REGISTRATION DATE _____

ENGINE MAKE & MODEL _____

SERIAL NUMBER _____

PART NUMBER _____

FUEL CAPACITY _____

WATER CAPACITY _____

KEY NUMBER, IGNITION _____ DOOR _____

SELLING DEALER _____

CITY & STATE _____

LENGTH _____ BEAM _____ DRAFT _____

VERTICAL CLEARANCE _____

ESTIMATED WEIGHT _____

GENERATOR SERIAL # _____ MODEL # _____ KILOWATTS _____



3. INSPECTION, SERVICE AND MAINTENANCE PROTOCOL

A. BILGE AREA

Many of your boat's systems have critical features located in the bilge area. A thorough and organized inspection of the bilge area will address many of these critical features. For example, engine oil leaks and fuel system leaks will show themselves as contamination on the surface of the liquid that remains in the bilge. When you see such contamination, you should look for its source.

Once or twice a year, pump the bilge areas dry and remove all loose dirt. Be sure that all the limber holes are open. Limber holes are the openings in the stringers that allow water to flow from the outboard areas of the bilge to the bilge sump.

Check the bilge pump float switch by moving it manually. (See Fig. 4.1.2) The bilge pump should start when the float switch is raised and should stop when lowered. If it does not, first try resetting the bilge pump breakers, if the pump will still not run replace the float switch before using your boat. The float switch should also move freely without sticking, if it does not, have it serviced or replaced before boating.

 **WARNING**

DO NOT USE FLAMMABLE SOLVENTS to clean any part of the bilge.

Fumes can accumulate and can be the source of an explosion.

1. OIL

If there is oil contamination, look for leaks in engine oil lines and engine gaskets. If parts of the bilge have been stained by oil, the stain can be removed using a bilge cleaner available from your dealer or a marine store.

2. ENGINE

Engine failure or malfunction, when away from shore, can be dangerous. Make certain you do the following each time you use the boat:

- Wipe off the engine to remove accumulated dust, grease and oil.
- Check all exposed nuts, bolts and screws for tightness.
- Inspect the belts for wear. If they do not require replacement, check and adjust the belt tension according to the engine manufacturer's recommendation.
- Inspect engine wiring, and clean and tighten the terminals on the engine electrical system.
- Clean and lubricate the battery cables.
- Add distilled water to the battery cells as needed.
- Refer to your Engine Operator's Manual for additional engine maintenance requirements.

3. FUEL SYSTEM

- Inspect the entire fuel system for evidence of leakage, including the fuel tank fill lines and vents. Any stain around a joint could be an indication of a leak.
- Test all fittings with a wrench to be sure they are not loose, but do not forcefully overtighten the fittings.
- Clean fuel filters and vent screens.

 **WARNING**

Work on electrical wiring can create shock hazards or sparks.

Always shut off battery switch, breakers and/or pull fuses before checking electrical wiring or connectors.



SECTION 8 • REQUIRED INSPECTION, SERVICE & MAINTENANCE

4. WIRING SYSTEM

- Check all wiring for proper support.
- Check all wiring insulation for signs of fraying or chafing.
- Check all terminals for corrosion - corroded terminals and connectors should be replaced or thoroughly cleaned.
- Tighten all terminals securely and spray them with light marine preservative oil.

5. FITTINGS, HOSES AND CLAMPS

- Inspect the entire bilge area for evidence of damage or deterioration. Evidence of deterioration will first appear around hull fittings, hoses and clamps.
- Straighten kinked hoses.
- Replace any hose that does not feel pliable.
- Check all hose clamps for tightness and corrosion. Corroded clamps must be replaced.
- Check the nuts, bolts and screws that retain equipment, hoses, etc. in the bilge for tightness and corrosion. Corroded fasteners must be replaced.

B. TOPSIDE AND SUPPLIES

Once a year, you should undertake a thorough review of the topside equipment, as well as of the critical safety supplies on your boat.

- Check cleats, rings, rails, etc. for loose or corroded fasteners, breaks, sharp edges or other conditions that could lead to malfunction or unsafe use. Repair or replace as necessary.
- Inspect PFDs (life jackets) for tears and deterioration.
- Make certain you have enough PFDs on board for the maximum number of persons you can carry.

- Check your first aid kit, making certain it is complete and that the items in it have not passed an expiration date.
- Check the signaling equipment and emergency flares. Make sure all items are within their expiration dates.
- Inspect the anchor, mooring and towing lines. Repair or replace as required.
- Check fire extinguishers for full charge.

4. WINTERIZATION CHECKLIST FOR BOATS STORED ON LAND

A. BOAT STORAGE

- Store boat in a bow high attitude.
- Remove hull drain plug.
- Pour one (1) pint (half-liter) of 50% water/antifreeze mixture in each bilge pump sump.

B. ENGINES

- Flush engines with fresh water.
- Remove engine drain plugs.

REFER TO YOUR ENGINE OPERATOR'S MANUAL FOR DETAILED INFORMATION ON PREPARING THE ENGINES FOR STORAGE AND WINTERIZATION.

C. BATTERY(IES)

- Remove from boat. Remove the negative (-) cable first, then the positive (+) cable.
- Remove grease and dirt from top surface.
- Grease terminal bolts.
- Store on wooden pallet or thick plastic in a cool dry place. Do not store on concrete.



SECTION 8 • REQUIRED INSPECTION, SERVICE & MAINTENANCE

- Keep under a trickle charge.
- When placing battery back into service, remove excess grease from terminals, recharge as necessary and reinstall in boat.

F. FUEL SYSTEMS

GASOLINE:

- Fill fuel tank with gasoline and the recommended amount of stabilizer and conditioner such as “Stabil®”.
- Run engine(s) for ten minutes to ensure that all gasoline in the carburetor and fuel lines are treated.

DETAILED WINTERIZING, OPERATING INSTRUCTIONS AND WARRANTY INFORMATION ARE PROVIDED BY THE EQUIPMENT MANUFACTURER AND CAN BE FOUND IN THE OWNER’S PACKET.

**CAUTION**

Do not overfill. Filling a tank until the fuel flows from vents is dangerous. Allow room for expansion.

5. FITTING OUT AFTER STORAGE

A. FUEL SYSTEM

Check the entire fuel system for loose connections, worn hoses, leaks, etc. and repair. This is a primary safety precaution.

Check fuel lines for damage and make sure that they do not come in contact with any moving parts.

B. BATTERY(IES)

Before installing the batteries, clean the terminal posts with a wire brush or steel wool and then attach the cables. After the cable clamps are tightened, smear the post and clamps with vaseline or grease to exclude air and acid. Do not apply grease before attaching and tightening the terminal clamps. Examine all wiring.

C. MISCELLANEOUS

- Check all thru-hull fittings for unobstructed water passage. Be alert for any deteriorated hoses and/or fittings below the water line which might fail in service and admit water.
- Test the navigation lights.
- Check all wiring for loose connections.
- Check all switches and equipment for proper operation.
- Check bilge blowers for proper operation. Turn ON blowers and place hand over hull blower vent to make sure air is coming from vent.
- Anchor lines and gear should be inspected and replaced if necessary.
- Make sure the hull drain plug is in place and tight.
- Clean bilge thoroughly if it was not done at lay-up.
- Check all engine fluid levels.
- Check fuel lines for damage and/or leaks. Make sure that they do not come into contact with moving parts.

6. SECURITY CONSIDERATIONS

Be conscious of the security of your boat. Always remove the keys from the ignition, lock hatches, remove and stow any removable electronic gear (fish finders, GPS, etc.) and personal gear (fishing poles, etc.) normally left aboard your boat.



8. QUICK REFERENCE CHECKLIST

As the owner/operator of a Sea Ray® boat, you are responsible for the safe operation of your boat and the safety of your passengers. Always be sure that required documents, navigational equipment and Coast Guard required safety equipment is aboard and in proper working order.

A. BOARDING THE BOAT*

GENERAL

1. Weather Conditions Is it going to be safe to go out
2. Transom Drain Plug Installed
3. PFDs and all other Coast Guard
required safety equipment Available for all children and adults
4. Ignition keys Available
5. Tool Box Stocked with a variety of appropriate tools

BOAT SYSTEMS

1. Bilge Pumps Working. Discharge any appreciable amounts of water overboard
2. Blowers Working. "Sniff" the bilge/engine compartment for fuel odor
3. Navigation Lights Working. Have spare bulbs (and if applicable fuses) aboard
4. Radio/Electronics Working
5. Horn Working

ENGINE

1. Batteries Fully charged (Check water cell levels)
2. Fuel Tank Filled with recommended fuel
3. Fuel System Check for leaks
4. Fuel Filters Check that filters are clean and tight
5. Engine Coolant Drain Plug Secured
6. Steering Fluid Full
7. Throttle & Gearshift Control Test Full range of motion

***Note:** Many of these items should be checked before leaving the house.



QUICK REFERENCE CHECKLIST (CONT'D)

B. PREPARING TO DEPART AND AFTER LAUNCHING

GENERAL

1. Bilge/Engine Compartment “Sniff” the bilge/engine compartment for fuel odor.
Run the bilge blowers for at least four (4) minutes.
2. Lines, Fenders and Anchor..... Ready for use
3. Passengers/Crew Instructed in duties for getting underway and fitted for a correct size PFD

ENGINE

1. Battery Switch (if installed) In the ON position
2. Engine Alarm Test. Should sound after a few seconds
3. Gear Shift & Throttle Control In NEUTRAL and IDLE positions

STARTING THE ENGINE*

1. Gearshift & Throttle Control Shift in NEUTRAL (Refer to your Engine Owner’s Manual for start-up procedures for your specific engine)
2. Ignition Turn ignition key clockwise, as in a car, and release when engine starts.

IMPORTANT: Do not crank engine for more than a few seconds if it doesn’t start. Engine may be very cold or flooded.

 **WARNING**

Do not run the engine or generator in an enclosed area, such as a closed boat house, as there is the possibility of buildup and inhaling of carbon monoxide.

*If engine fails to start, refer to the Engine Owner’s Manual for further troubleshooting procedures



QUICK REFERENCE CHECKLIST (CONT'D)

C. WHILE UNDERWAY

GENERAL

1. Passengers/Crew Safely seated with PFD's on or immediately accessible
2. Lines, Fenders and Anchor..... Stowed

BOAT SYSTEMS

1. Navigation Lights On at night or in reduced visibility

ENGINE

1. Tachometer Engines operating in safe RPM range
2. Engine Gauges..... Continually monitor
3. Engine Operation..... Check idle and shift. Listen for abnormal noises and visually check the engine compartment while underway

D. RETURNING TO PORT

GENERAL

1. Passengers/Crew Instructed in duties for line handling
2. Lines and Fenders..... Ready for use

BOAT SYSTEMS

1. Navigation Lights Turned OFF when secured
2. Anchor Light ON if necessary
3. Bilge/Engine Compartment "Sniff" the bilge/engine compartment for fuel odor. Run the bilge blowers if necessary. Check for water in bilge. Run bilge pumps if necessary

ENGINE

1. Throttle & Gearshift Control..... Bring to IDLE and NEUTRAL positions
2. Tachometer..... Idle the engines for five (5) minutes to cool down
3. Ignition Turn OFF ignition key
4. Engine Operation..... Check idle and shift. Listen for abnormal noises



QUICK REFERENCE CHECKLIST (CONT'D)

E. SECURING THE BOAT

GENERAL

1. Lines and Fenders..... Fenders in place, lines tied securely to dock

BOAT SYSTEMS

1. Helm Switch Panel..... All switches in the OFF position
2. Gearshift & Throttle Control..... In the NEUTRAL and IDLE positions

ENGINE

1. Ignition..... Switched in the OFF position
2. Battery Switch (if installed)..... In the OFF position

F. IF THE ENGINE DOES NOT START

NO STARTER MOTOR RESPONSE

1. Check gearshift control lever in the NEUTRAL position
2. Check battery condition for sufficient charge
3. Check battery cable connections tight and free from corrosion
4. Check battery switch in the ON position
5. Check starter motor and solenoid connections
6. Check ignition switch connections

STARTER MOTOR RESPONDS, BUT NO IGNITION

1. Check that fuel tank is not empty
2. Check that fuel filter is clean
3. Check electrical connections on engine wiring harness and ignition wiring



SECTION 9 • CARE & REFINISHING

Your new boat has been designed to provide you with years of enjoyment and satisfaction. In order to maintain the factory new appearance of your boat, we recommend the use of 3M™ Marine's one step Maintenance and Reconditioning Products designed specifically for pleasure boats. Following proper fiberglass maintenance guidelines will help maintain your boat's performance, value, and enjoyment.

1. PAINT CLEANING AGENTS AND OTHER SUBSTANCES

 **WARNING**

EXPLOSION/FIRE HAZARD

Care and refinishing materials may contain ingredients that are flammable or explosive. Do not use such materials in the bilge

Shut off electrical power and ventilate when using such materials anywhere on the boat or in the cabin.

Do not create sparks or use lighted materials.

Do not use products containing chlorine, phosphates, perfumes and nondegradable ingredients. Consult your marine dealer regarding environmental regulations before painting the hull. Fumes can last for hours, and chemical ingredients can harm people, property and the environment. Common household cleaning agents may cause hazardous reactions. Read and understand directions on all paint, cleaning and polishing materials before using.

2. FIBERGLASS AND GELCOAT

The fiberglass hull, deck and some interior parts consist of a molded shell and exterior gelcoat. The gelcoat is the outer surface, often colored, that presents the shiny smooth appearance associated with fiberglass products. This gelcoat surface is painted or taped in some areas for styling purposes.

Wash the gelcoat and fiberglass regularly with clean, fresh water. Wax gelcoated surfaces to maintain the luster. In northern climates, a waxing at the start and end of the boating season may suffice. In southern climates, an application of wax every three months will be required for adequate protection.

REFER TO THE "3M® ONE STEP MAINTENANCE AND RECONDITIONING PRODUCTS" PAMPHLET IN YOUR OWNER'S MANUAL PACKET FOR INSTRUCTIONS AND WARRANTY INFORMATION.

 **WARNING**

Gelcoat surfaces are slippery when wet.

Always wear nonslip footwear securely fastened to your feet and hold on to rails or the boat structure.

 **WARNING**

Waxed surfaces are slippery.

Do not wax areas that are usually walked on.

A. KEEP BILGE AREA DRY

Water may accumulate in the engine room where it is not able to drain to the bilge pump. Check all areas of the engine room for accumulated water and dry thoroughly. Water left standing may penetrate through the gelcoated surfaces and wick into the fiberglass affecting the life of the product.



SECTION 9 • CARE & REFINISHING

3. STAINS AND SCRATCHES

Although gelcoat and painted surfaces are resistant to deep stains, a need for cleaning will occasionally arise. But, the use of some common cleaning agents will permanently discolor or otherwise damage the finish on your boat.

- Do not use abrasive porcelain-cleaning powders. These are too abrasive and contain chlorine and ammonia, either of which will permanently discolor gelcoat and paint.
- Never use nail polish remover (acetone) or any ketone solvents.
- Use diluted household detergents to remove surface soil and stains. Before using a given brand, check to make sure it contains no chlorine or ammonia.
- Alcohol can be used to remove difficult stains. But it must be promptly washed off with mild detergent and water.
- Minor scratches and deeper stains that do not penetrate the gelcoat may be removed by light sanding and buffing.

4. PERMANENTLY MOORED OR DOCKED BOATS

If permanently moored in salt water or fresh water, your boat will collect marine growth on its bottom. This will detract from the boat's beauty and greatly affect its performance. There are two methods of preventing this:

- Periodically haul the boat out of the water and scrub the bottom with a bristle brush and a solution of soap and water.
- Paint the hull below the waterline with a good

grade of antifouling paint. **DO NOT** paint the engine drive surfaces.

NOTE: There are EPA regulations regarding bottom paint application. Consult your Sea Ray® dealer for proper application methods.

5. CARE FOR BOTTOM PAINT

From time to time a slight algae or slime forms on all vessels. The bottom painted portion of the hull can be wiped off with a coarse Turkish towel or a piece of old rug while the boat is in the water. Do not use a stiff or abrasive material to clean the bottom paint.

The bottom paint should be inspected annually. If it needs repainting consult your Sea Ray® dealer.

6. TOPSIDE AREAS

A. STAINLESS STEEL AND ALLOY FITTINGS

Stainless steel and alloy fittings should be cleaned with soap and water or household glass cleaner. Remove rust spots as soon as possible with a brass, silver or chrome cleaner. Irreversible pitting will develop under rust that remains for any period of time. Never use an abrasive like sandpaper or steel wool on stainless. These may actually cause rust. To help protect the stainless, we recommend the use of a good car wax.

B. SALT CRYSTALS

When instruments are exposed to a saltwater environment, salt crystals may form on the bezel and the plastic covers. These salt crystals should be removed with a soft, damp cloth; never use abrasives or rough, dirty cloths to wipe plastic parts. Mild household detergents or plastic cleaners can be used to keep the instruments bright and clean.

REFER TO THE OWNER'S MANUAL PACKET FOR INSTRUCTIONS AND WARRANTY INFORMATION.



SECTION 9 • CARE & REFINISHING

7. GAUGE AND SWITCH PANELS

No special care is needed. Just wipe off with a soft, fresh water damp cloth to remove dust or salt. Dry after with chamois or soft cloth. Use of protective chemicals is not required.

NOTE: Do not use any chemicals to clean or protect gauge lenses.

8. ACRYLIC PLASTIC SHEETING (PLASTIC GLASS)

Never use a dry cloth or duster or glass cleaning solutions on acrylic.

To clean acrylic, first flood it with water to wash off as much dirt as possible. Next, use your bare hand, with plenty of water, to feel and dislodge any caked dirt or mud. A soft, grit-free cloth may then be used with a nonabrasive soap or detergent. A soft sponge, kept clean for this purpose, is excellent. Blot dry with a clean damp chamois.

Grease and oil may be removed from acrylic with kerosene, hexane, white (not aviation or ethyl) gasoline or aliphatic naphtha (no aromatic content).

Do not use solvents such as acetone, silicone spray, benzine, carbon tetrachloride, fire extinguisher fluid, dry cleaning fluid or lacquer thinner on acrylic, since they attack the surface.

Remove fine scratches with fine automotive acrylic rubbing and polishing compounds.

9. CANVAS AND CLEAR VINYL

Do not fold or store any of the canvas pieces while wet. All canvas should be rolled or folded when dry and stored in a clean, dry place. For clear vinyl pieces, the recommended methods for storage are rolling or laying down flat. The clear vinyl should never be folded or creased as cracking will result. To protect the clear vinyl from rubbing against itself while rolled or stored flat, place a piece of very soft, nonabrasive cloth between the pieces. If the surface of the clear vinyl becomes scratched, the canvas manufacturer has provided a canvas care sheet located in your Owner's Manual Packet. When storing the rear (aft) curtain, fold the canvas over the clear vinyl window (do not fold clear vinyl), then roll or store flat.

The fabric should be cleaned regularly before substances such as dirt, pollen, etc. are allowed to accumulate on and become embedded in the fabric. The fabric can be cleaned without being removed from the installation. Simply brush off any loose dirt, particles, etc.; hose down and clean with a mild solution of a natural soap in lukewarm water (no more than 100°F, 38°C); rinse thoroughly to remove soap. **DO NOT USE DETERGENTS.** Allow to completely dry.

Wash and clean vinyl windows with a warm soap solution. Use a soft cloth or sponge and do not scratch the surface.

If you have stubborn cleaning cases, call your dealer for proper procedures. Do not try your own cleaning procedures as they may permanently damage the canvas.

After each use, especially in salt water areas, rinse the canvas completely with fresh cold water. Then let the canvas dry completely before stowing.

All metal components of the canvas should be rinsed



10. EXTERIOR UPHOLSTERY FABRIC

Exterior fabrics should be cleaned with a sponge or very soft scrub brush and a mild soap and warm water solution. After scrubbing, rinse with plenty of cold, clean water and allow the fabric to air dry in a well ventilated place, preferably away from direct sunlight.

Mildew can occur if your boat does not have adequate ventilation. Heat alone will not prevent mildew; you must also provide for fresh air circulation.

REFER TO THE OWNER'S MANUAL PACKET FOR INSTRUCTIONS AND WARRANTY INFORMATION.

NOTICE

Always clean spots, stains, etc., immediately. Test an unseen area of fabric before cleaning stain, to insure that cleaning material will not cause damage.



INDEX

SYMBOLS

12 Volt Accessory Receptacle 6.3

B

Batteries..*See* Electrical System - DC

Bilge

Blower 4.2

Layout..... 4.7

Maintenance..... 4.2,8.4

Pump..... 4.1

Boarding 3.3

Bottom Paint 9.2

Breakers & Fuses..*See* Electrical System

Builder's Plate..... 1.6

C

Canvas 7.3,9.3

Carbon Monoxide 1.2

Certifications

CE (Common European) mark..... v

NMMA (National Marine Manufacturers Assoc.).. v

Clearances 2.3

Cleats 2.1

Compass 2.9

D

Dimensions..... 2.3

Diving..... 1.10

Docking..... 2.1

E

Electrical Schematics 6.5

Electrical System - DC

Accessory Fuse Block..... 6.3

Batteries 6.1

Battery Cable Routing 6.2

Fuses 6.2

Electrolytic Corrosion..... 6.4

Emergency Situations..... 1.11

Engine

Maintenance..... 8.4

Maintenance and Service..... 4.3

Starting..... 3.4

Stopping 3.6

Engine Alarm..... 2.9

Entertainment Center 7.1

Environmental Considerations..... 1.13

F

Failure: Propulsion, Control or Steering..... 1.12

Fiberglass, Care & Cleaning..... 9.1

Fire Extinguisher..... 1.2

Fire Extinguisher Port..... 7.1

Fire Extinguisher System..... 7.2

Fire Extinguishing System 1.2

Flooding..... 1.12

Fuel System

Anti-Siphon Valve 5.1

Fueling 3.2

Fuel Fill..... 5.2

Fuel Gauge 2.9

Maintenance..... 8.4

Static Electrical Discharge 5.2

Fuses..... 6.2

G

Gear Shift and Throttle Control..... 2.7

Gelcoat, Care & Cleaning..... 9.1

H

Horn..... 7.4

Hull

Identification Number (HIN)..... iv

Through-Hull Cutouts 2.6

I

Ignition Protection..... 6.2

Inspection Summary Guide 8.1



INDEX

L

Layout	
Bilge	4.7
Deck	2.4
Helm, Gauges & Switches	2.5
Lighting.....	6.4
Passenger Locations.....	2.2
Lifesaving Equipment	1.4
Lifting.....	2.1
Lights	
Exterior.....	6.4
Lights, Navigation and Anchor.....	2.10
Load Capacity.....	1.5

M

Maintenance, Summary Guide.....	8.1
Maintenance Log.....	8.12

N

Nautical Terms.....	1.15
---------------------	------

O

OEM	i
Oil Pressure.....	
2.9. <i>See also</i> Layout: Helm, Gauge & Switches	
Owner's Manual Packet	i

P

Personal Flotation Devices (PFDs).....	1.2,1.4,3.3
Power Capacity.....	1.6
Power Trim	2.8
Propellers	1.6,4.4
Removal and Installation	4.4
Propulsion System.....	2.7

R

Recommended Equipment.....	1.5
Requirements	
International Requirements.....	1.13
Required Equipment	1.2

S

Safety Labels.....	1.1
Safe boating	1.1
Service, Summary Guide	8.1
Service Information	8.3
Skiing.....	1.9
SmartCraft™	2.9
Stability.....	1.7
Stains.....	9.2
Steering System	3.6
Stern Drive	2.7,4.3
<i>See also</i> Engine	
Storage	2.1
Swimming.....	1.9
Symbols.....	1.16

T

Tachometer. <i>See</i> Layout: Helm, Gauge & Switches	
---	--

U

U.S. Coast Guard (USCG).....	1.13
Upholstery	9.4

V

Visual Distress Signals.....	1.2
------------------------------	-----

W

Warning Label Locations	1.17
Warranties	iv,vi
Waste Disposal.....	1.14
Water Sports.....	1.9
Water Temperature	2.9
<i>See also</i> Layout: Helm, Gauge & Switches	
Weather	1.8
Winterizing.....	8.5

Z

Zinc Anodes.....	6.4
------------------	-----

