

BUILDER'S CERTIFICATION AND FIRST TRANSFER OF TITLE

I. PHASE OF CONSTRUCTION COVERED BY THIS CERTIFICATE

- ENTIRE CONSTRUCTION
 HULL ONLY
 COMPLETION ONLY (HULL BUILT BY ANOTHER)

YEAR PHASE OF CONSTRUCTION _____
 YEAR COMPLETED 2007

II. VESSEL DATA

- A. HULL IDENTIFICATION NUMBER
 OR HULL NUMBER SERV7750E707-185SP-05250
 B. VESSEL NAME (IF KNOWN)

D. PLACE OF BUILD (CITY, STATE, COUNTRY)
Monroe, Tennessee USA

- C. EQUIPPED WITH ENGINE?
 YES NO OUTBOARD YES NO

- E. HULL MATERIAL: WOOD STEEL FIBROUS REINFORCED PLASTIC
 ALUMINUM CONCRETE OTHER

III. DIMENSIONS (COMPLETE APPROPRIATE DIAGRAM)

SHIP-SHAPE HULL

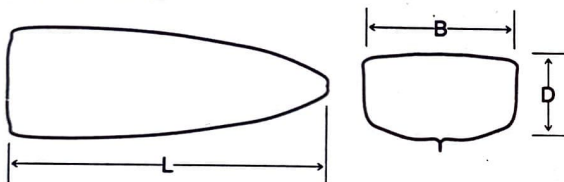

L= 17' 4 0" B= 6' 10 0" D= 2' 9 5"

SAILBOAT

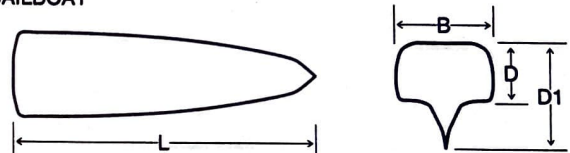

D1 only if actual hull depth (D) cannot be determined

L= _____ B= _____ D= _____ D1= _____

CATAMARAN

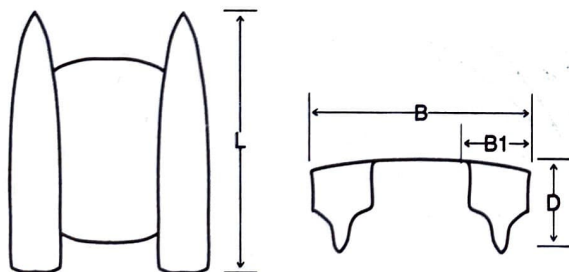

L= _____ B= _____ B1= _____ D= _____

TRIMARAN

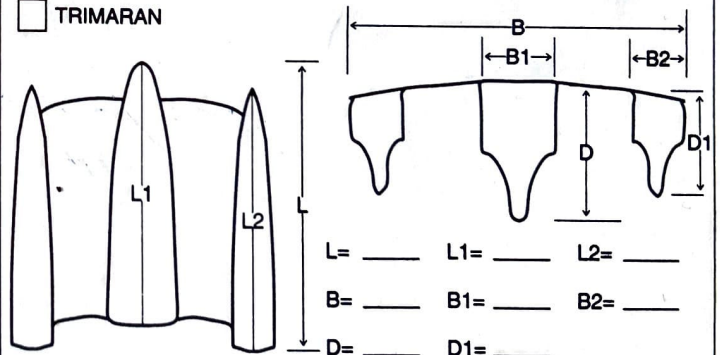

L= _____ L1= _____ L2= _____
 B= _____ B1= _____ B2= _____
 D= _____ D1= _____

BARGE-SHAPED HULL

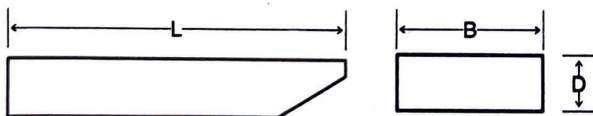

L= _____ B= _____ D= _____

DECKHOUSE

Houseboats only

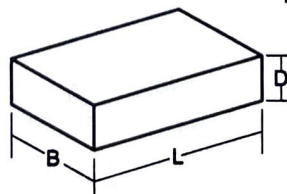

(AVERAGE DECKHOUSE
 DIMENSIONS MUST BE
 FURNISHED IN ADDITION
 TO HULL DIMENSIONS)

L= _____ B= _____ D= _____

IV. UNITED STATES BUILD STATEMENT

- ALL MAJOR COMPONENTS USED IN THE PHASE OF CONSTRUCTION COVERED BY THIS CERTIFICATE WERE FABRICATED IN THE UNITED STATES.
 ALL CONSTRUCTION AND ALL ASSEMBLY FOR THIS PHASE OF CONSTRUCTION WERE DONE IN THE UNITED STATES.

V. NAME(S) AND ADDRESS(ES) OR PARTY(IES) FOR WHOM BUILT

SERV7750E707-185SP-05250 Power Boats Center, NV (DEALER NUMBER) 1121
Noordkaai 30
Izegem, XX B-8870

IF BUILT FOR MORE THAN ONE PERSON, THE PERSONS NAMES ABOVE ARE TENANTS IN COMMON, EACH OWNING AN EQUAL UNDIVIDED INTEREST, UNLESS OTHERWISE INDICATED HEREIN: CHECK ONLY ONE OF THE FOLLOWING BLOCKS TO SHOW ANOTHER FORM OF OWNERSHIP.

- JOINT TENANCY WITH RIGHT OF SURVIVORSHIP TENANCY BY THE ENTIRETIES COMMUNITY PROPERTY
- OTHER (DESCRIBE)

VI. CERTIFICATION

I, Helen Gilbert DO HEREBY CERTIFY THAT THE FACTS RECITED HEREIN ARE TRUE AND THAT I HAVE PERSONAL KNOWLEDGE OF THESE FACTS BECAUSE I:

- PERSONALLY PERFORMED THE CONSTRUCTION
- OR SUPERVISED THE CONSTRUCTION AT AND ON BEHALF OF: SEA RAY DIVISION OF BRUNSWICK CORP. (NAME OF COMPANY)

ACTING IN MY CAPACITY AS Authorized Rep (TITLE) OF SEA RAY DIVISION OF BRUNSWICK CORP. (NAME OF COMPANY)

NOTE: THIS CERTIFICATE MUST NOT BE COMPLETED BY AN IMPORTER OR AN IMPORTER'S AGENT.

Helen Gilbert (SIGNATURE) 6/05/2007 (DATE)

VII. FIRST SALE OR TRANSFER OF VESSEL

100% OF THE VESSEL IDENTIFIED HEREIN IS SOLD (TRANSFERRED) BY THE PARTY(IES) NAMED IN SECTION V TO THE FOLLOWING PERSON(S) (NAMES AND ADDRESSES)

IF SOLD (TRANSFERRED) TO MORE THAN ONE PERSON, THE PURCHASER(S) (TRANSFERREE(S)) ARE TENANTS IN COMMON, EACH OWNING AN EQUAL UNDIVIDED INTEREST, UNLESS OTHERWISE INDICATED HEREIN: CHECK ONLY ONE OF THE FOLLOWING BLOCKS TO SHOW ANOTHER FORM OF OWNERSHIP.

- JOINT TENANCY WITH RIGHT OF SURVIVORSHIP TENANCY BY THE ENTIRETIES COMMUNITY PROPERTY
- OTHER (DESCRIBE)

VIII. SIGNATURE OF SELLER(S) (TRANSFEROR(S)) OR PERSONS SIGNING ON BEHALF OF SELLER(S) (TRANSFEROR(S))

DATE SIGNED:

IX. NAME(S) OF PERSON(S) SIGNING ABOVE, AND LEGAL CAPACITY IN WHICH SIGNED (E.G., OWNER, AGENT, TRUSTEE, EXECUTOR)

X. ACKNOWLEDGEMENT (TO BE COMPLETED BY NOTARY PUBLIC OR OTHER OFFICIAL AUTHORIZED BY A LAW OF A STATE OR THE UNITED STATES TO TAKE OATHS.)

ON _____ THE PERSON(S) NAMED IN (DATE)

STATE:

COUNTY:

SECTION IX ABOVE ACKNOWLEDGED EXECUTION OF THE FOREGOING INSTRUMENT IN THEIR STATED CAPACITY(IES) FOR THE PURPOSES THERIN CONTAINED.

NOTARY PUBLIC
MY COMMISSION EXPIRES

PRIVACY ACT STATEMENT

IN ACCORDANCE WITH 5 USC 562(A), THE FOLLOWING INFORMATION IS PROVIDED TO YOU WHEN SUPPLYING PERSONAL INFORMATION TO THE U.S. COAST GUARD.

- 1. AUTHORITY SOLICITATION OF THE INFORMATION IS AUTHORIZED BY 46 USC, CHAPTER 313 AND CFR, PART 67.
- 2. THE PRINCIPAL PURPOSES FOR WHICH THIS INSTRUMENT IS TO BE USED ARE (A) TO PROVIDE A RECORD, AVAILABLE FOR PUBLIC INSPECTION AND COPYING, OF THE SALE OR OTHER CHANGE IN OWNERSHIP OF A VESSEL WHICH IS DOCUMENTED, WILL BE DOCUMENTED, OR HAS BEEN DOCUMENTED PURSUANT TO 44 USC, CHAPTER 121. (B) PLACEMENT OF THIS INSTRUMENT IN A BOOK FOR EXAMINATION BY GOVERNMENTAL AUTHORITIES AND MEMBERS OF THE GENERAL PUBLIC.
- 3. THE ROUTINE USE WHICH MAY BE MADE OF THIS INFORMATION INCLUDES DEVELOPMENT OF STATISTICAL DATA CONCERNING DOCUMENTED VESSELS.
- 4. DISCLOSURE OF THE INFORMATION REQUESTED ON THIS FORM IS VOLUNTARY, HOWEVER, FAILURE TO PROVIDE THE INFORMATION COULD PRECLUDE FILING OF A BILL OF SALE AND DOCUMENTATION OF THE VESSEL NAMED HEREIN PURSUANT TO 46 USC, CHAPTER 121. MOREOVER, BILLS OF SALE WHICH ARE NOT FILED ARE NOT DEEMED TO BE VALID AGAINST ANY PERSON EXCEPT THE GRANTOR OR A PERSON HAVING ACTUAL KNOWLEDGE OF THE SALE (46 USC 31321(A)).